



US 20100053044A1

(19) **United States**

(12) **Patent Application Publication**

Lee et al.

(10) **Pub. No.: US 2010/0053044 A1**

(43) **Pub. Date: Mar. 4, 2010**

(54) **ORGANIC LIGHT EMITTING DIODE
DISPLAY AND METHOD FOR
MANUFACTURING THE SAME**

Publication Classification

(51) **Int. Cl.**
G09G 3/30 (2006.01)
(52) **U.S. Cl.** **345/80**

(76) Inventors: **Hae-Yeon Lee**, Bucheon-si (KR);
Baek-Woon Lee, Yongin-si (KR);
Young-In Hwang, Yongin-si (KR)

(57) **ABSTRACT**

An organic light emitting diode display panel includes a transparent substrate on which a matrix array of pixels is formed with each pixel including an organic light emitting diode (OLED). The OLEDs include light emitting regions sandwiched between pixel electrodes or anodes made of transparent conductive material and a common electrode made of a conductive material. The refractive index of the pixel electrodes is higher than the refractive index of the insulating layer on which the pixel electrodes are disposed so that light undergoes multiple reflections at the interface between the pixel electrodes and the insulating layer and also at the interface between the light emitting regions and the common electrode. The thickness of the pixel electrodes is chosen so that light that eventually exits the pixel electrodes after multiple reflections contains a relatively strong component of a chosen primary color.

Correspondence Address:
Haynes and Boone, LLP
IP Section
2323 Victory Avenue, SUITE 700
Dallas, TX 75219 (US)

(21) Appl. No.: **12/470,429**

(22) Filed: **May 21, 2009**

(30) **Foreign Application Priority Data**

Sep. 1, 2008 (KR) 10-2008-0085859

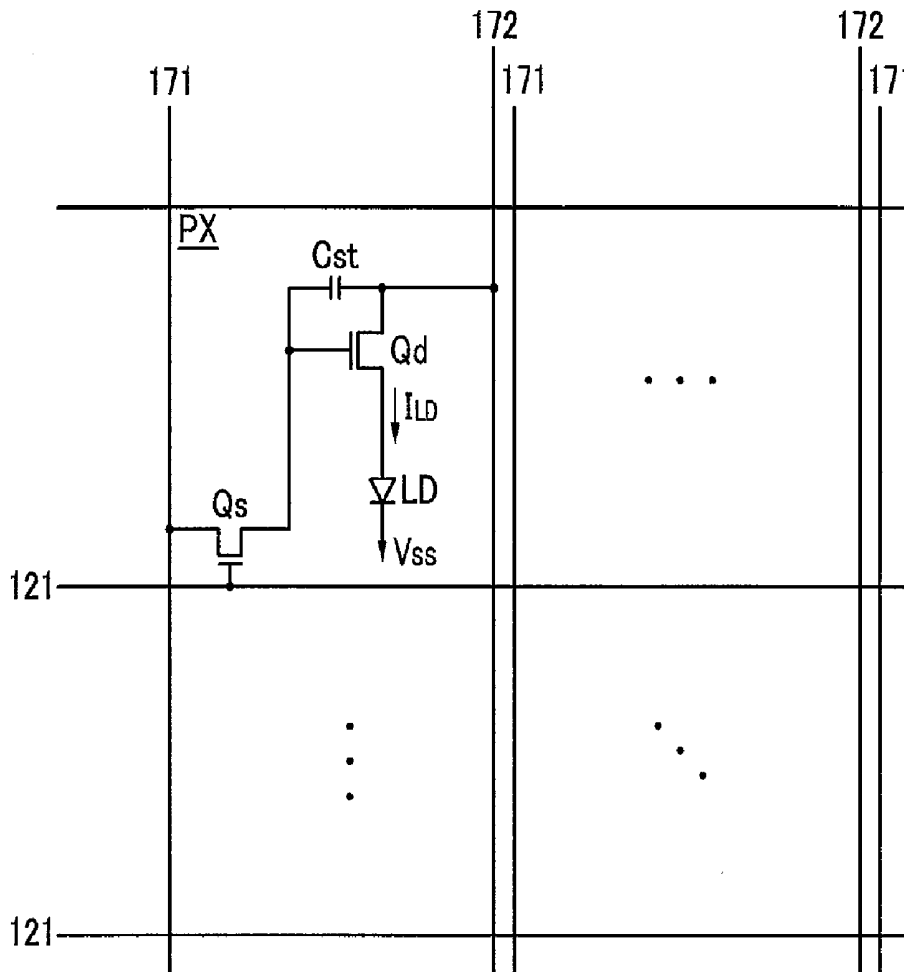

FIG. 1

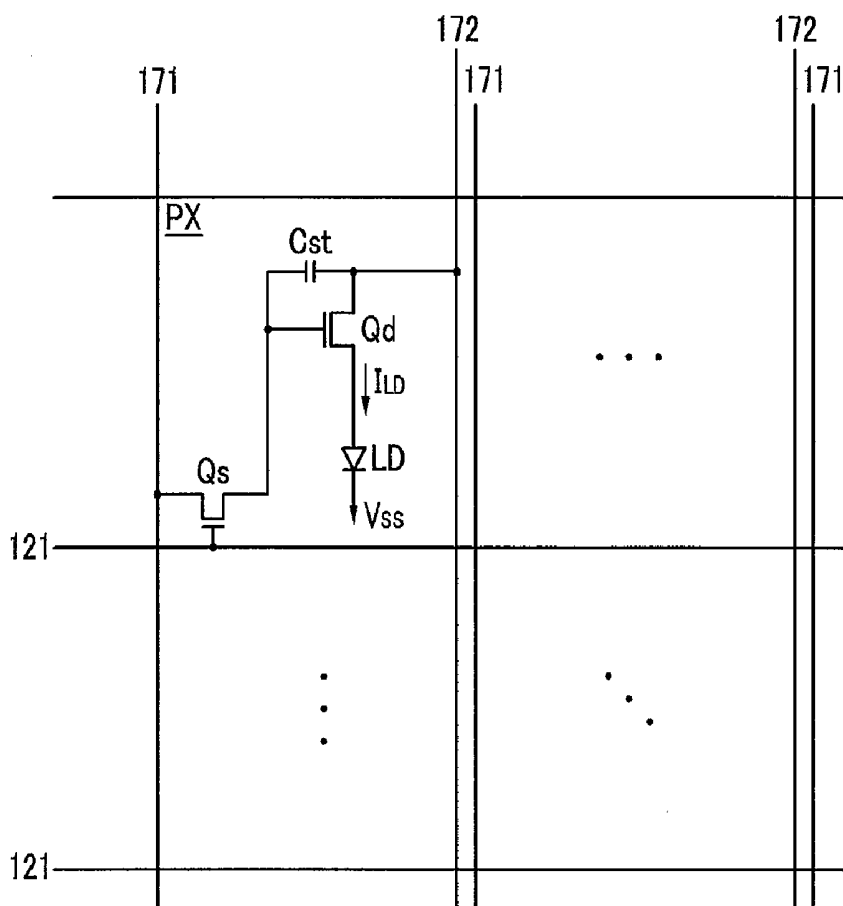

FIG. 2

B	W	B	W	B
G	R	G	R	G
B	W	B	W	B
G	R	G	R	G
B	W	B	W	B

The figure shows a 5x5 grid of cells. The letters in the cells are arranged in a checkerboard pattern. The top row contains B, W, B, W, B. The second row contains G, R, G, R, G. The third row contains B, W, B, W, B. The fourth row contains G, R, G, R, G. The bottom row contains B, W, B, W, B. A dashed line forms a 2x2 square around the top-left quadrant of the grid, specifically enclosing the cells (row 2, col 1), (row 2, col 2), (row 3, col 1), and (row 3, col 2).

FIG. 3

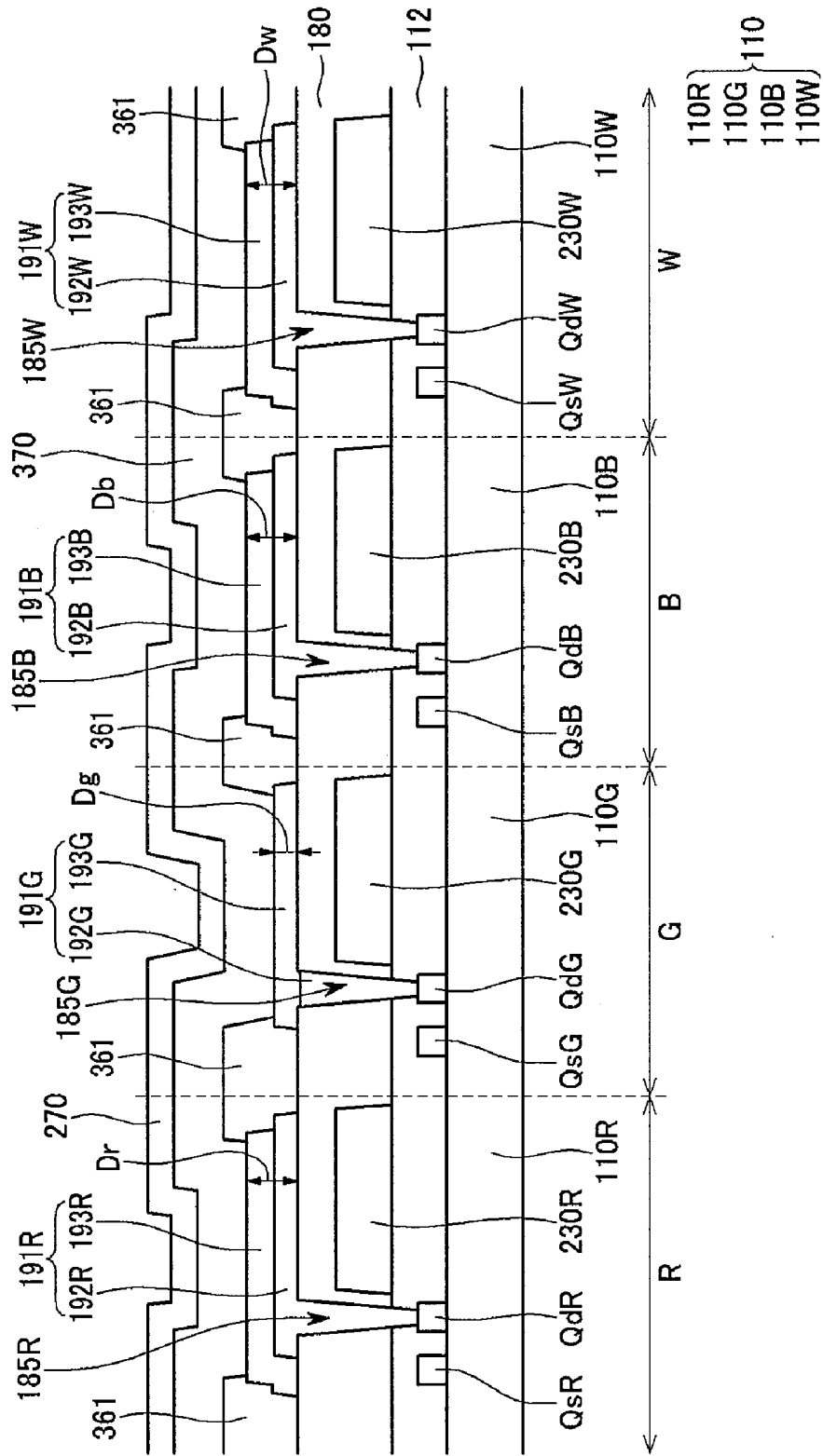

FIG. 4

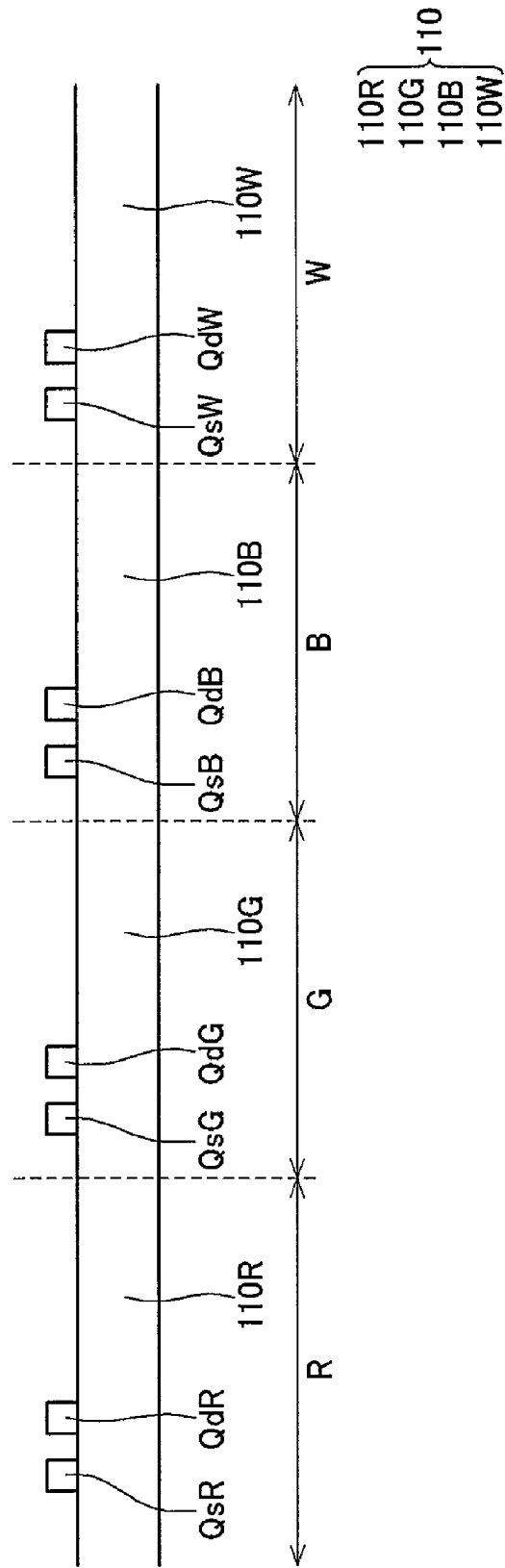

FIG. 5

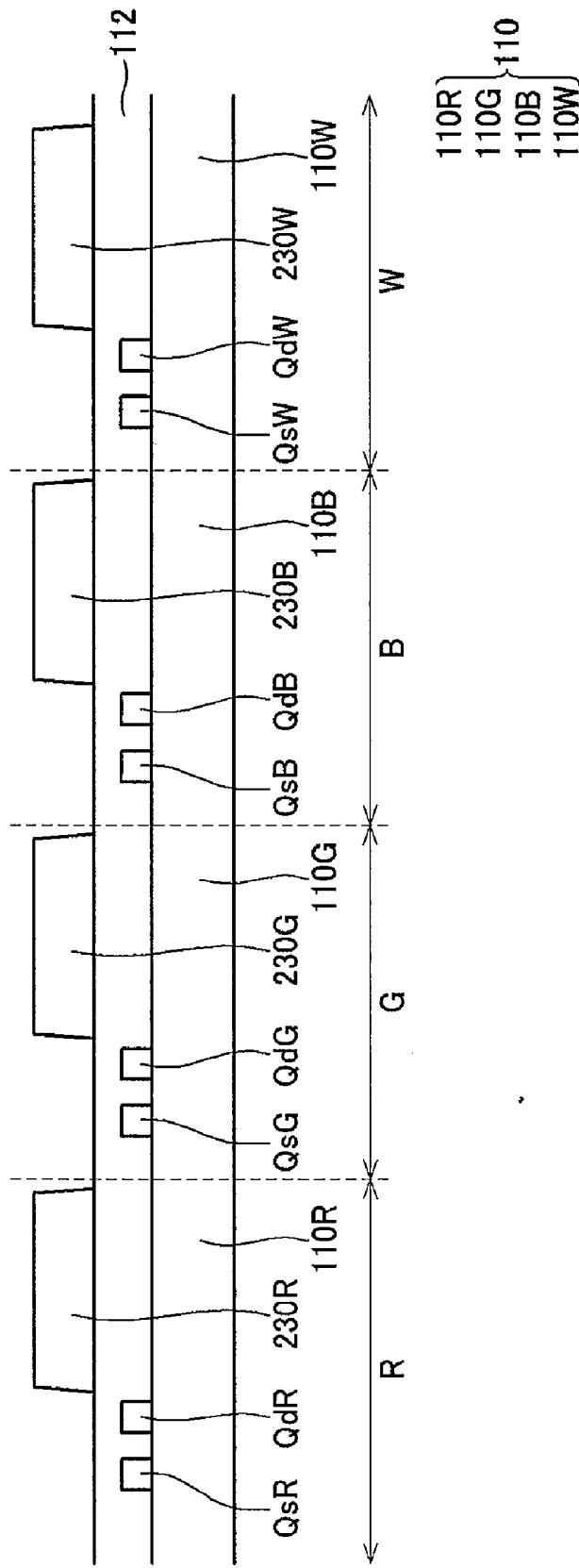

FIG. 6

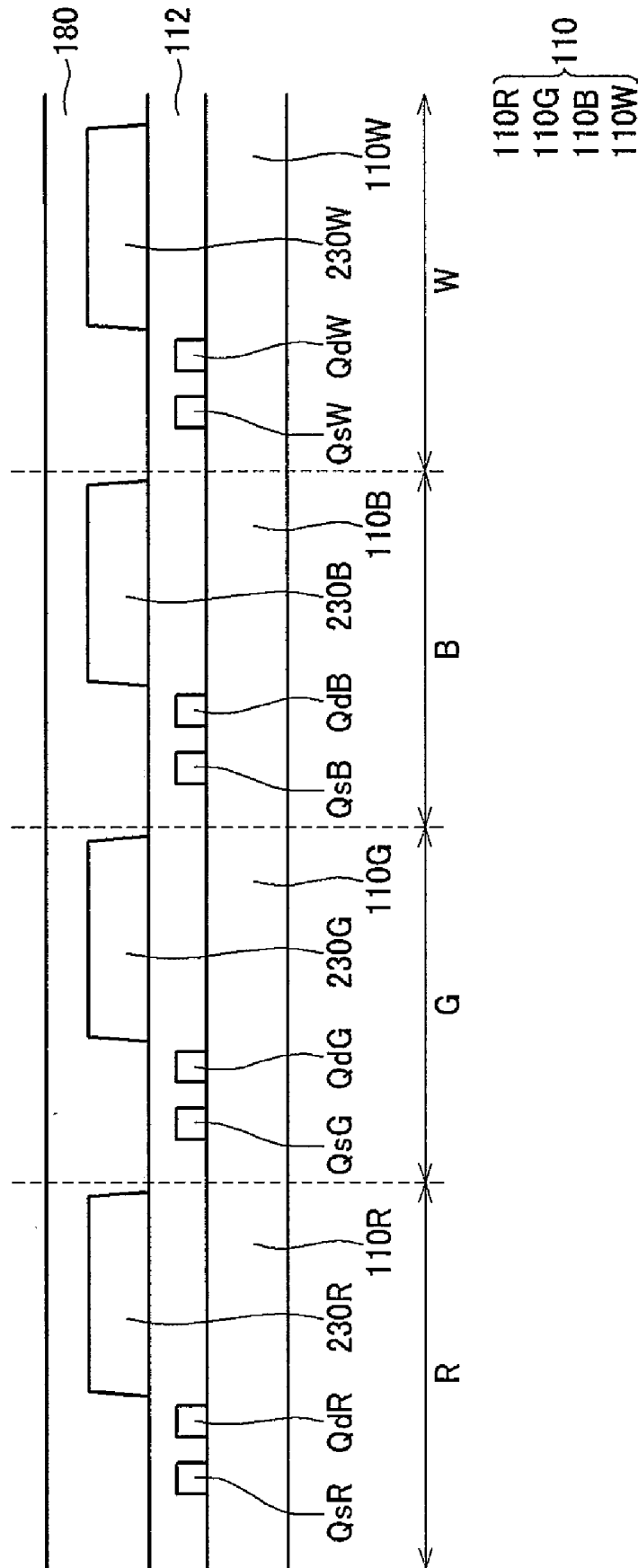

FIG. 7

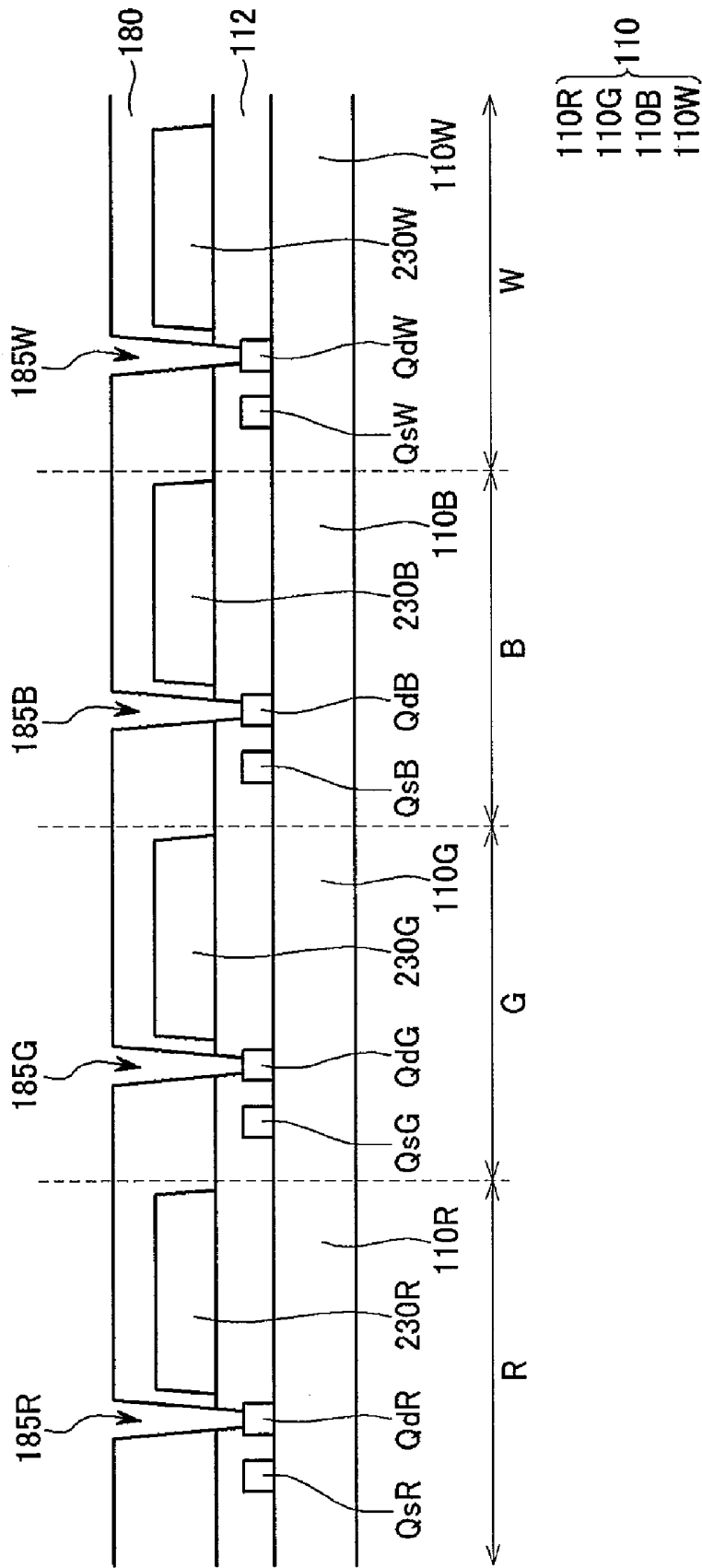

FIG. 8

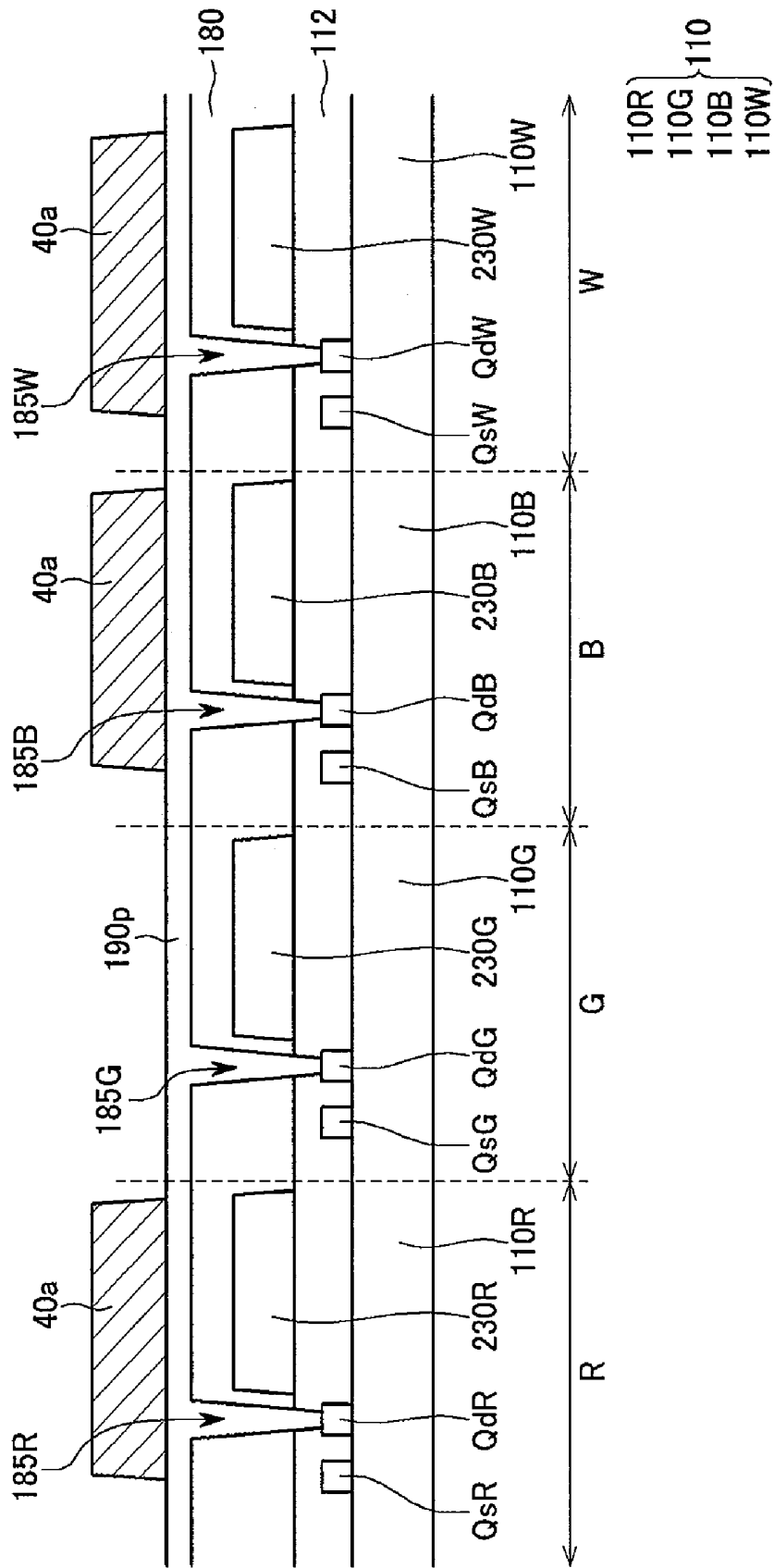

FIG. 9

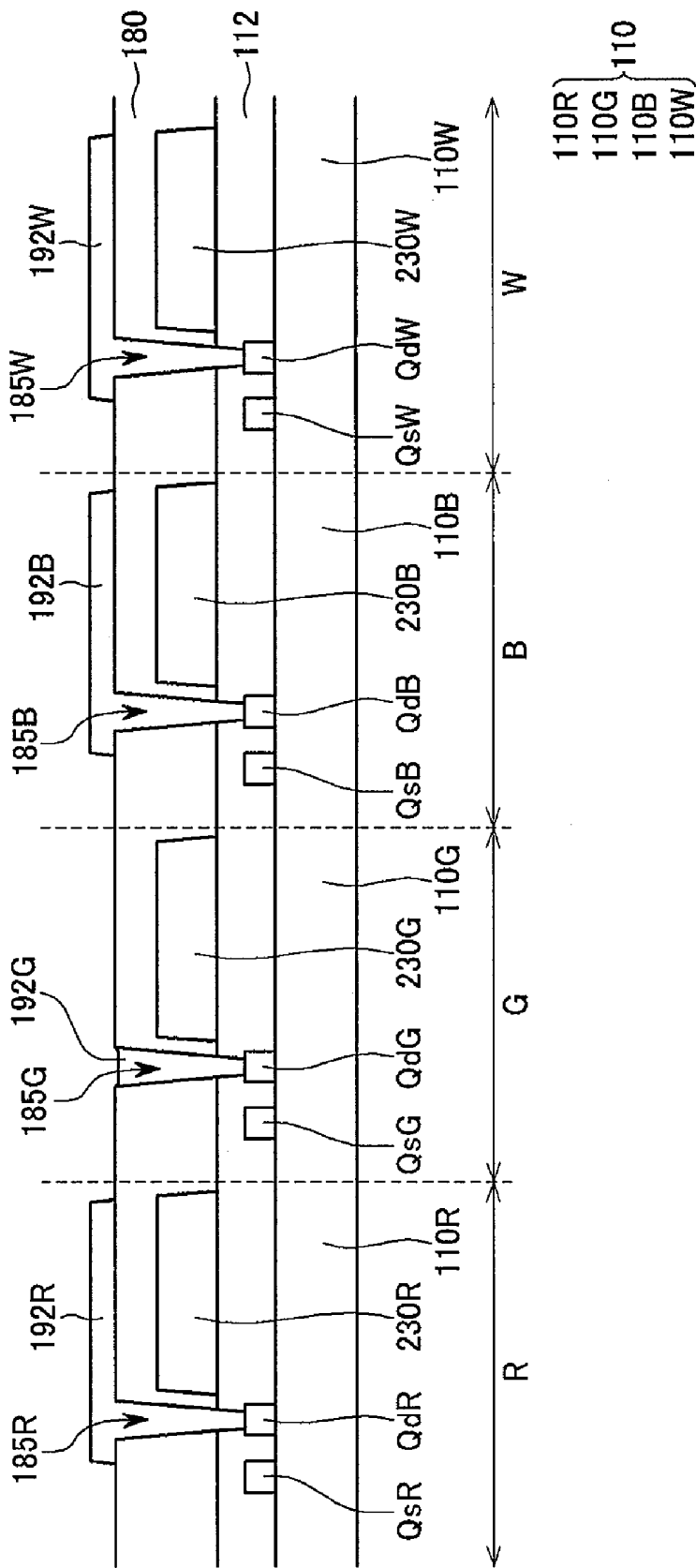

FIG. 10

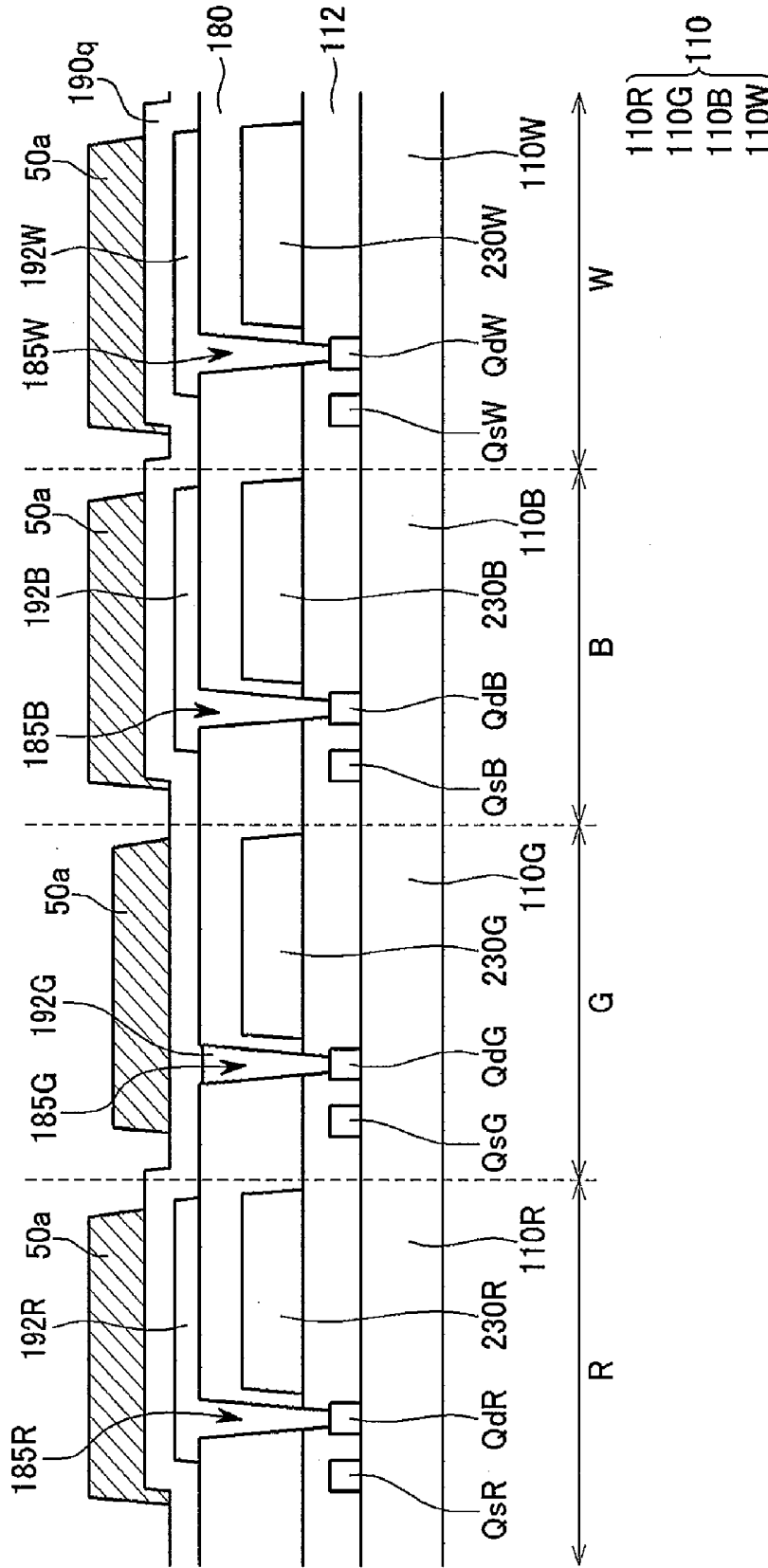

FIG. 11

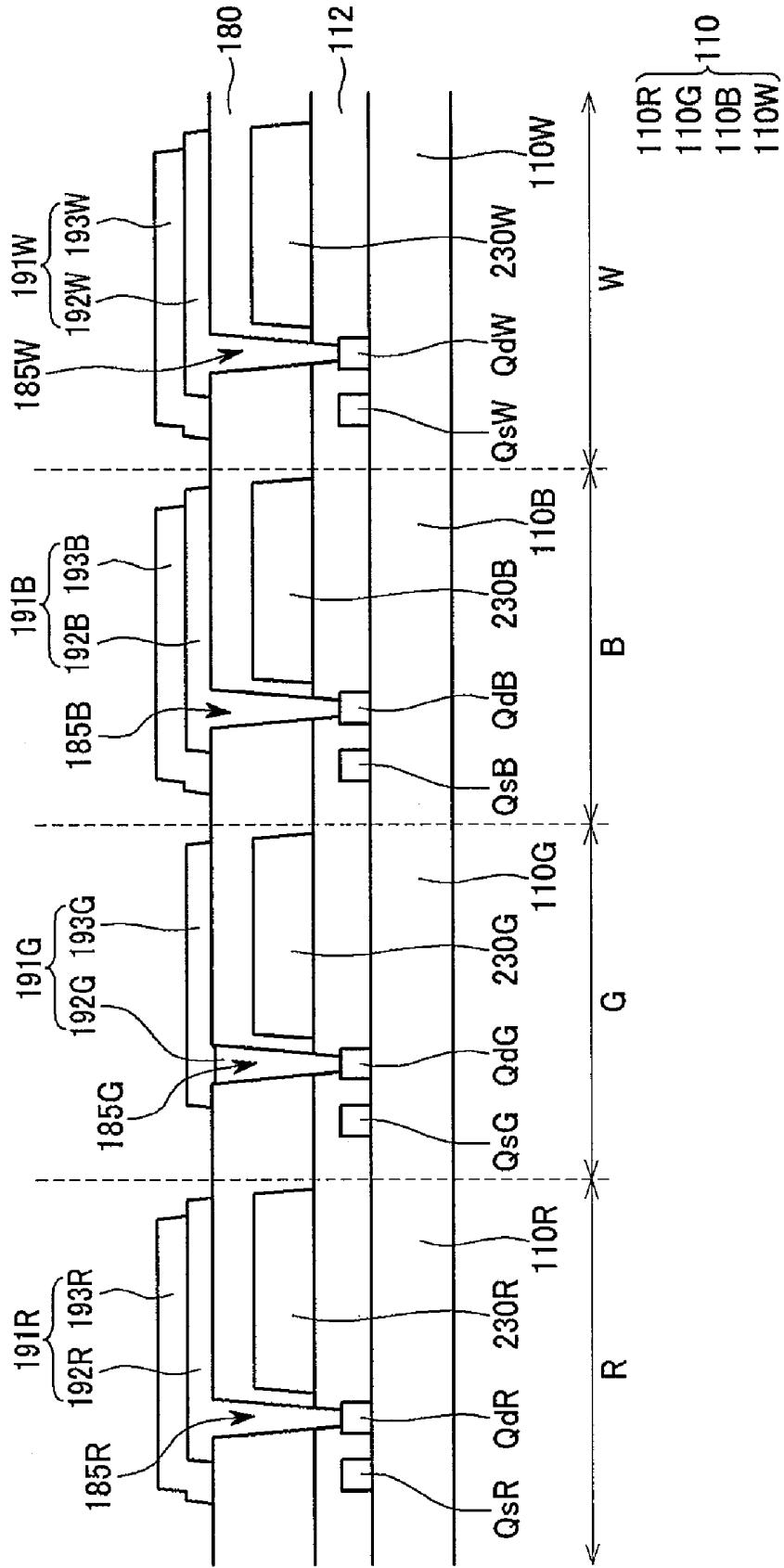

FIG. 12

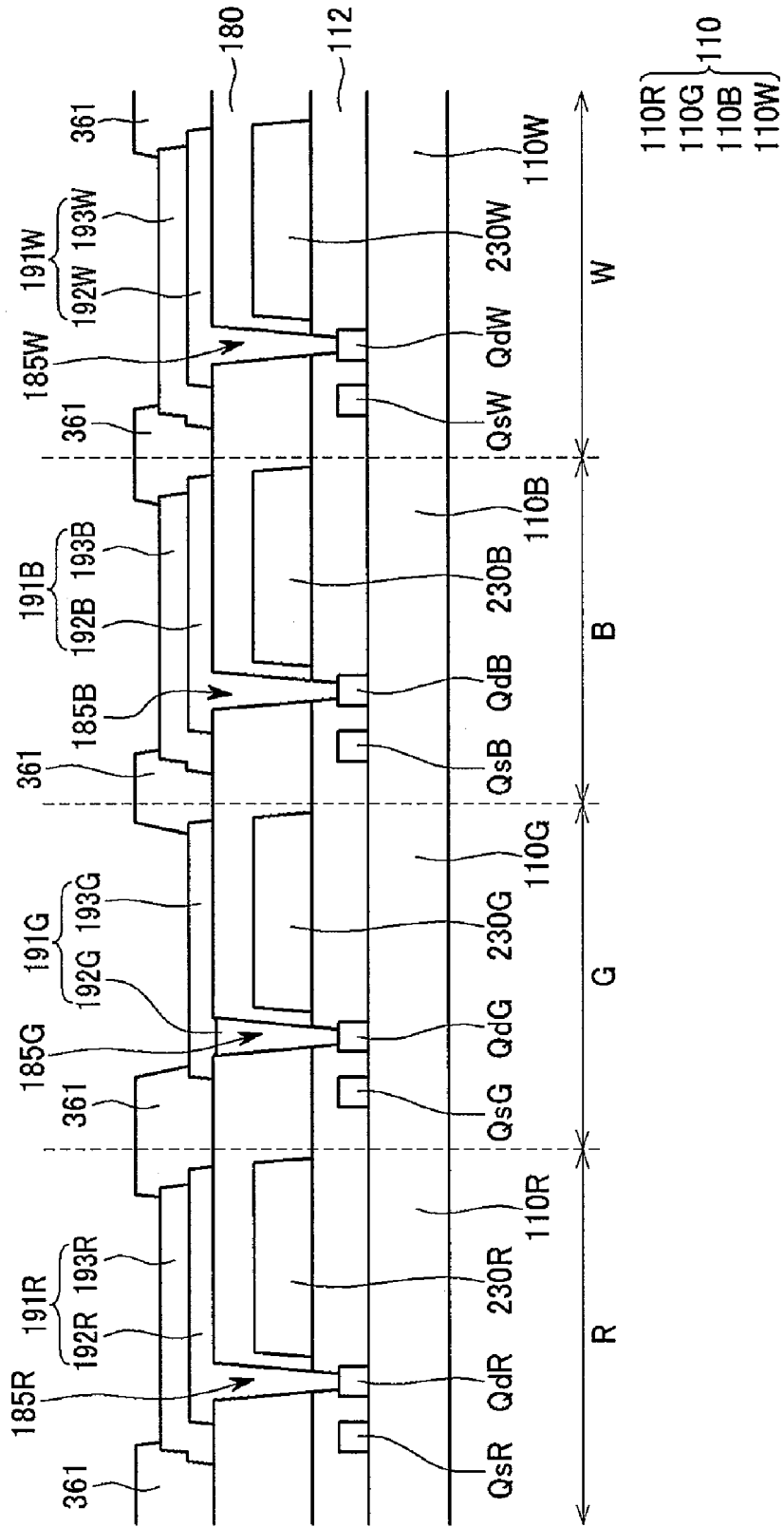

FIG. 13

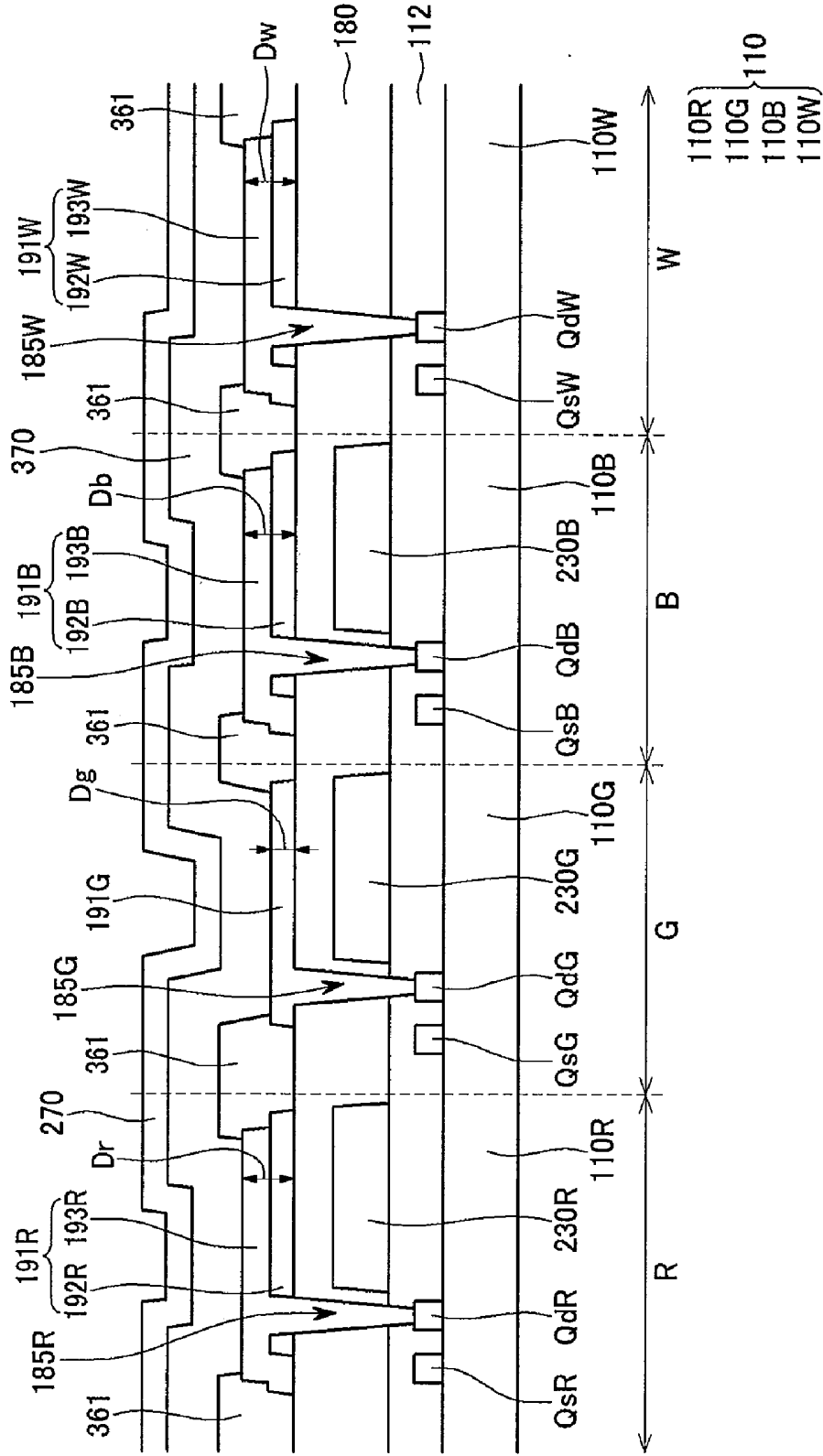

FIG. 14

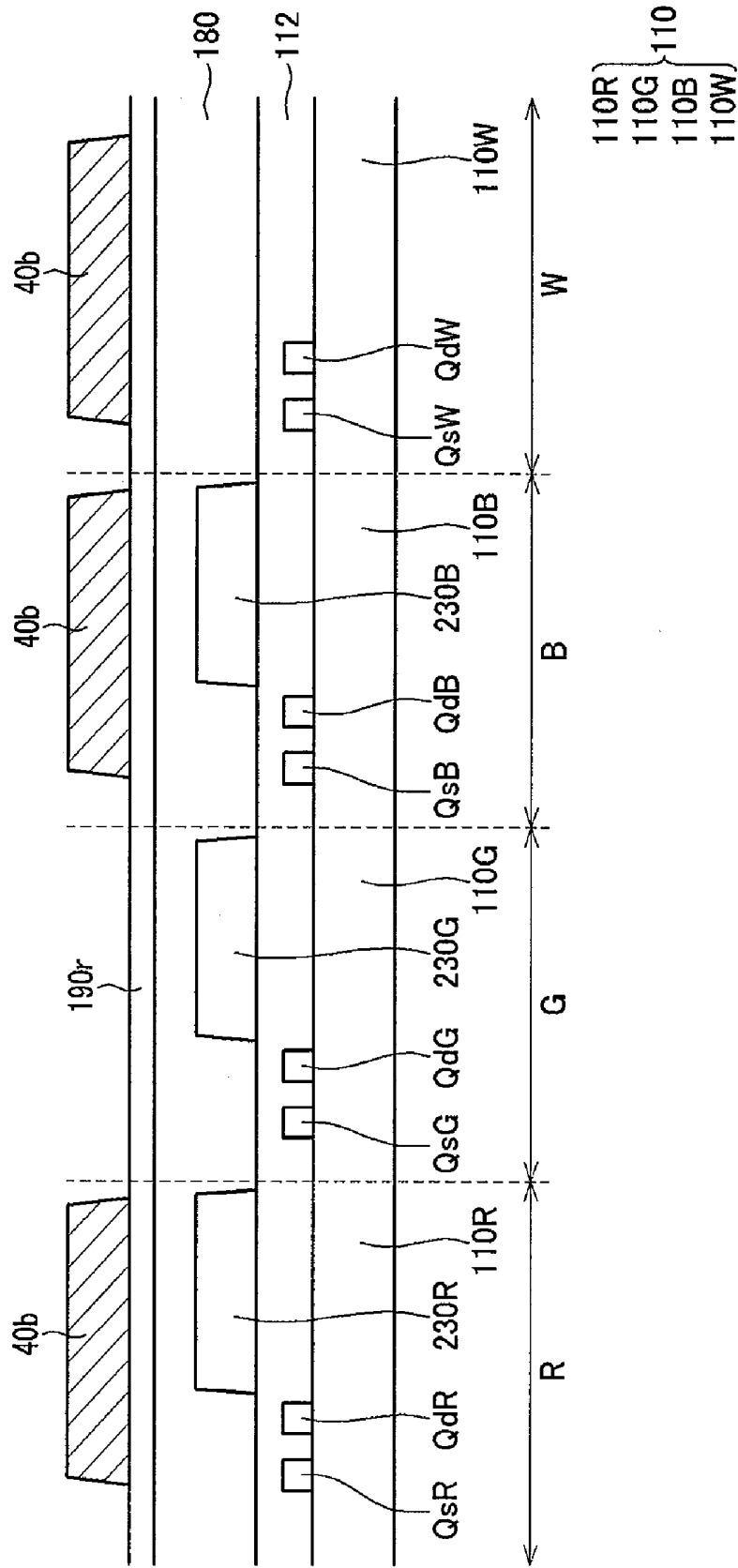

FIG. 15

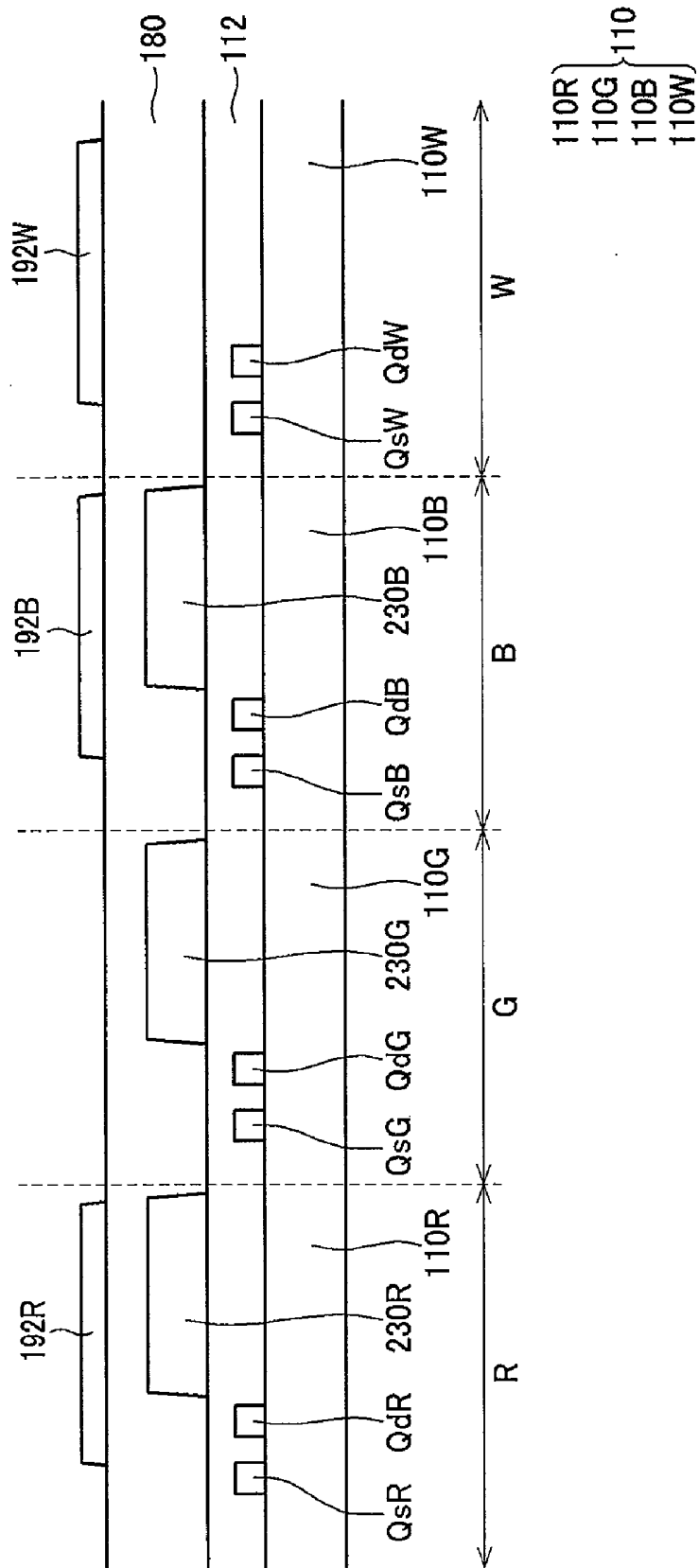

FIG. 16

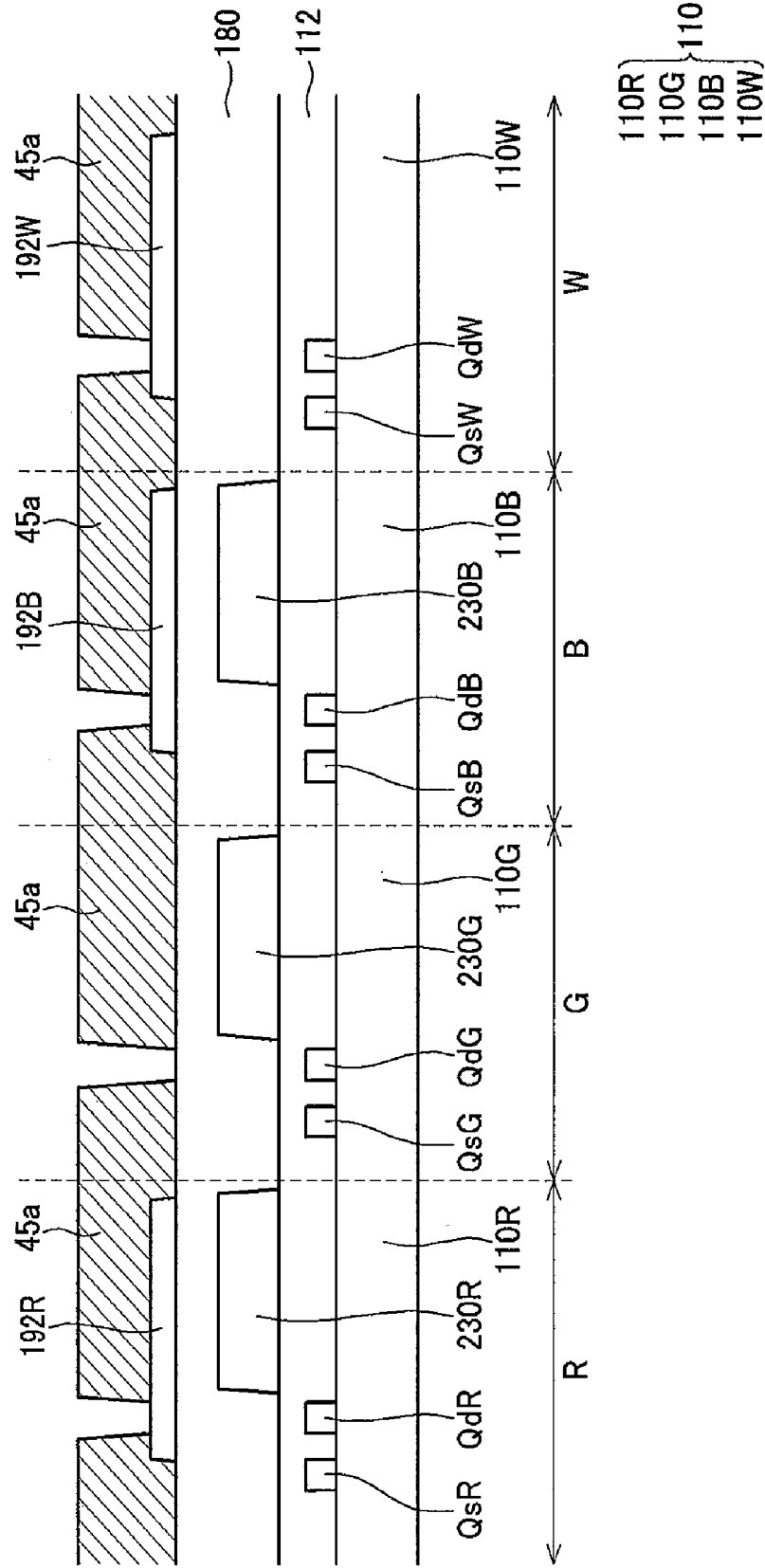

FIG. 17

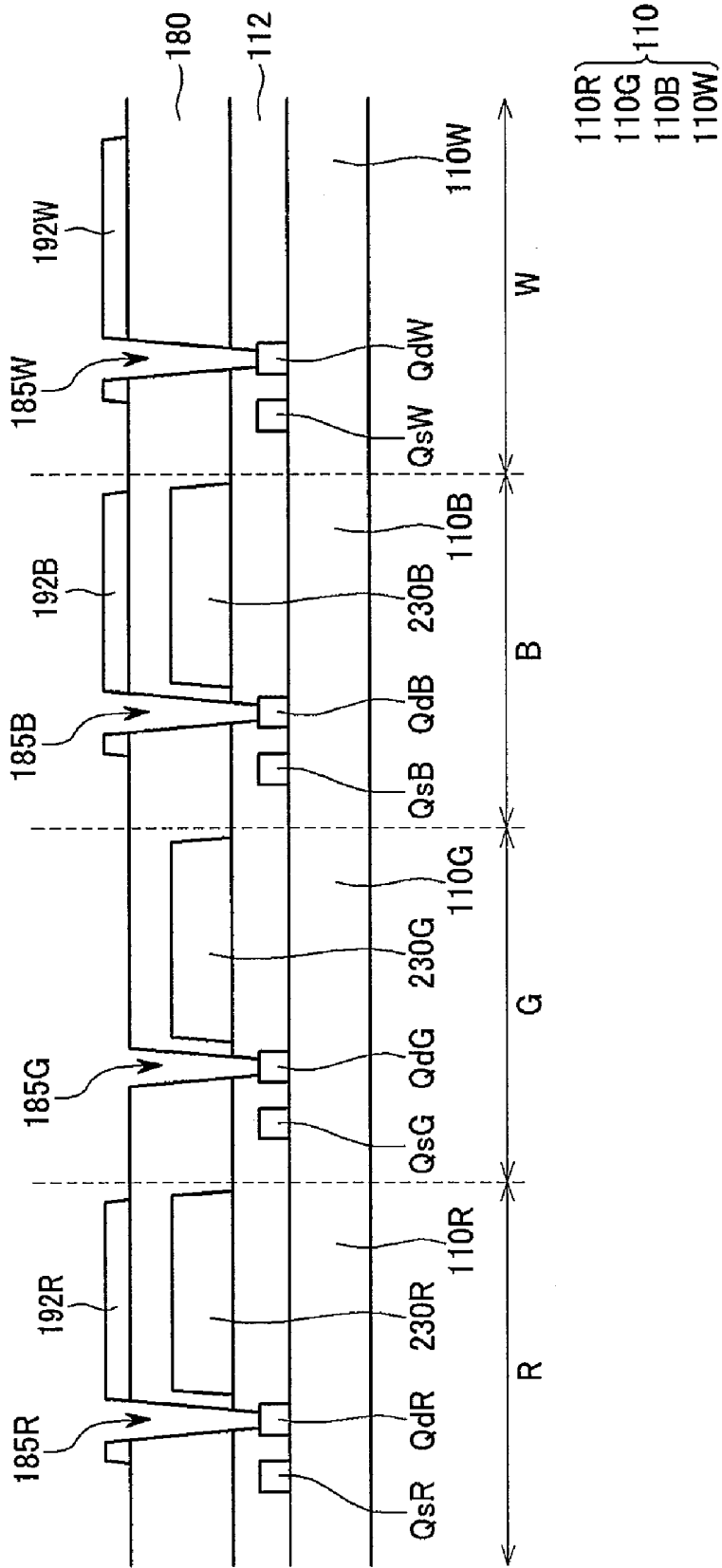

FIG. 18

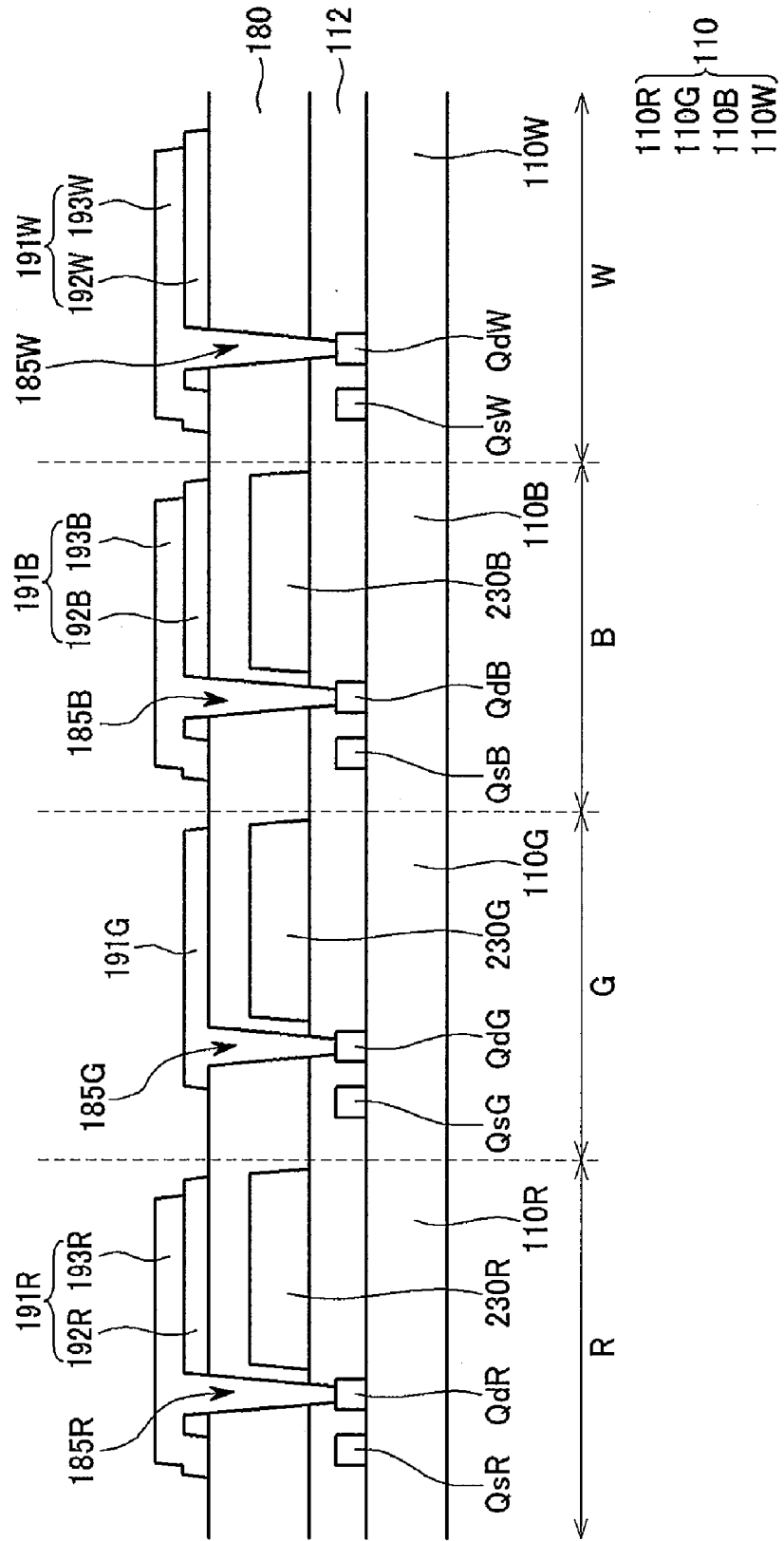

FIG. 20

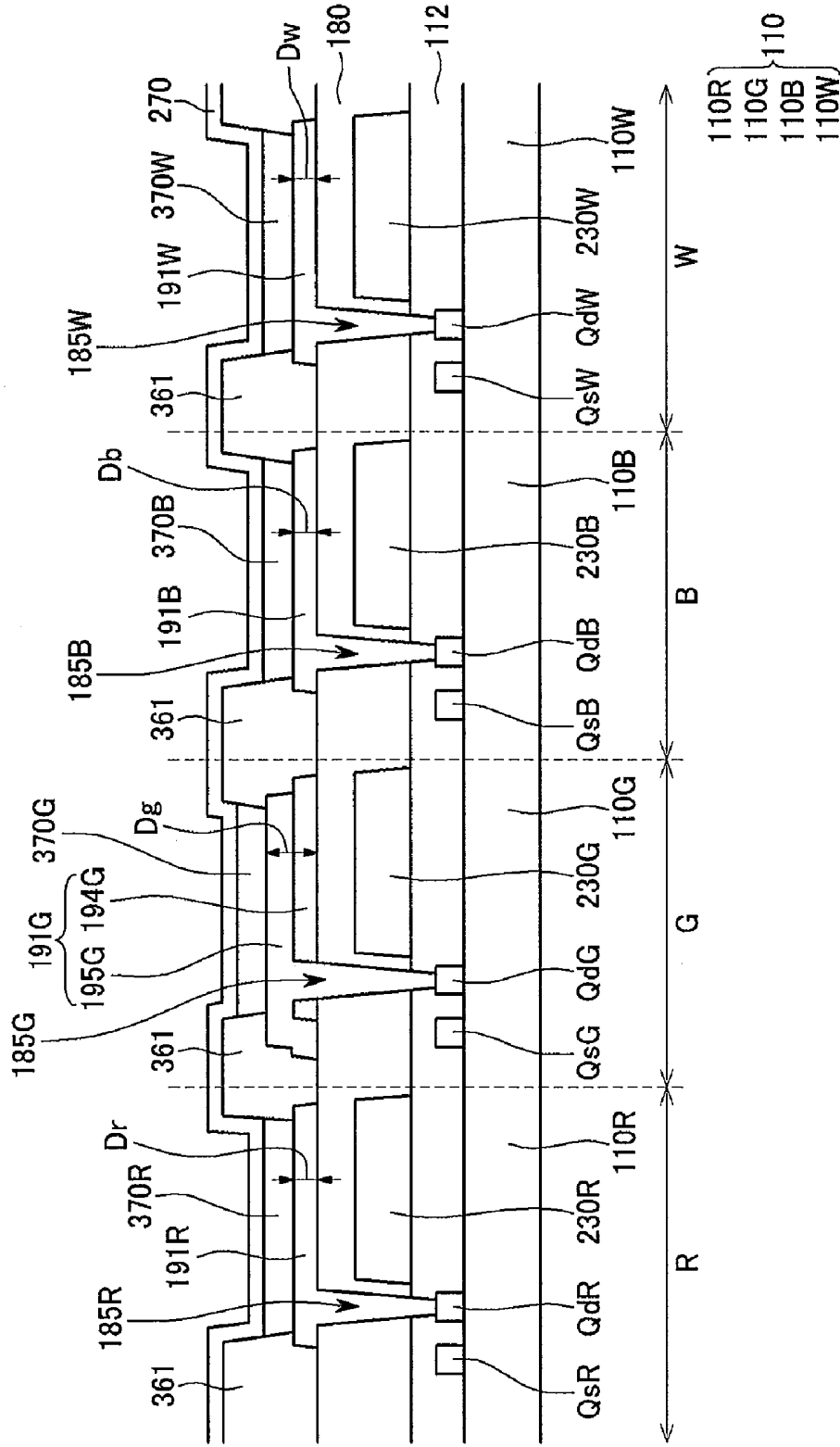
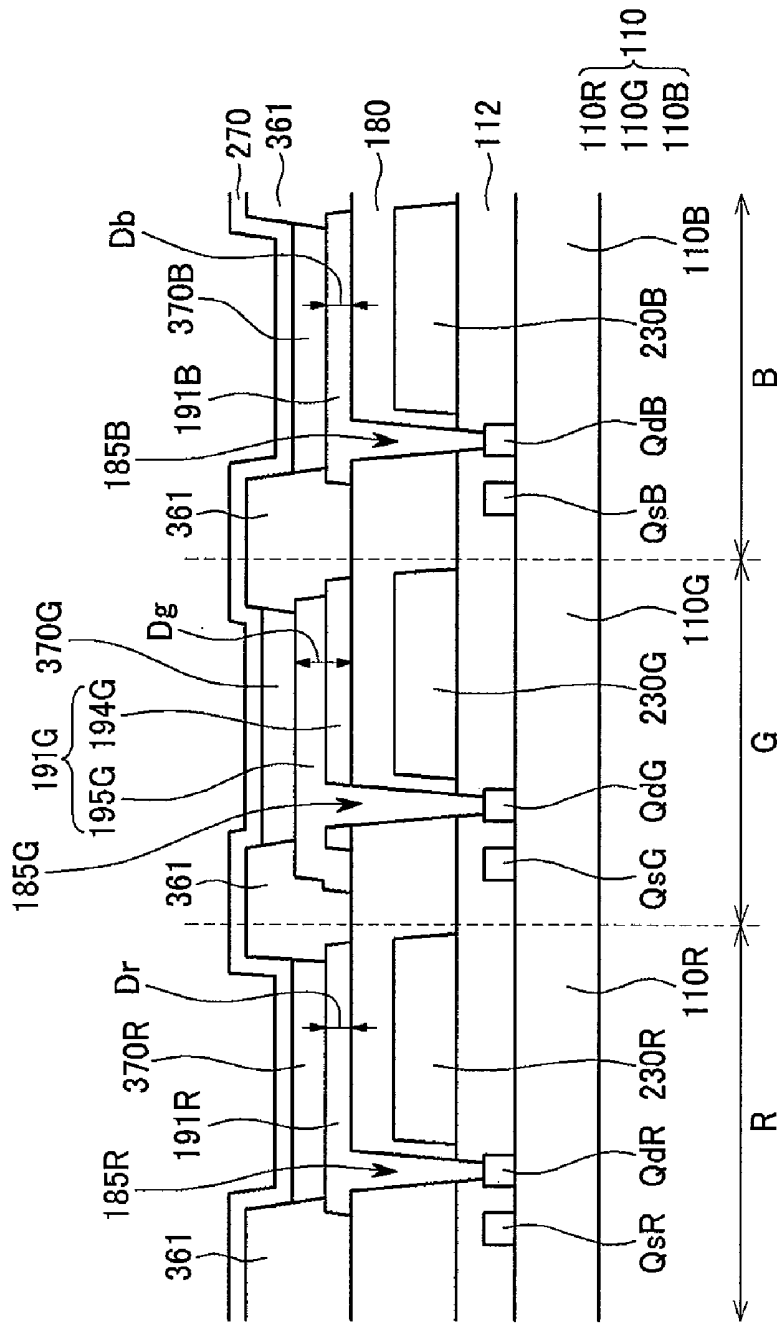

FIG. 21

G	B	R	G	B
B	R	G	B	R
R	G	B	R	G
G	B	R	G	B
B	R	G	B	R

FIG. 22



**ORGANIC LIGHT EMITTING DIODE
DISPLAY AND METHOD FOR
MANUFACTURING THE SAME**

CROSS-REFERENCE TO RELATED
APPLICATION

[0001] This application claims the benefit of priority of Korean Patent Application No. 10-2008-0085859 filed in the Korean Intellectual Property Office on Sep. 1, 2008, the contents of which are incorporated herein by reference.

BACKGROUND OF THE INVENTION

[0002] (a) Field of the Invention

[0003] The present invention relates to an organic light emitting device and a manufacturing method thereof.

[0004] (b) Description of the Related Art

[0005] Since an organic light emitting display (OLED) is a self emissive display, it does not require a light source. Therefore, the OLED consumes relatively less power than other displays. Also, the OLED has a fast response speed, a wide viewing angle, and an excellent contrast ratio.

[0006] The OLED includes a plurality of primary color pixels such as red pixels, blue pixels, and green pixels, and displays a full range of colors composed of the spatial sum of primary colors emitted through a combination of these pixels.

[0007] Each pixel of the OLED includes an organic light emitting element and a plurality of thin film transistors for driving the organic light emitting element.

[0008] The organic light emitting element includes an anode, a cathode, and an organic light emitting member interposed between the anode and the cathode. The organic light emitting member emits light of one of three primary colors, for example, red, green, and blue, or emits white light. A material of the organic light member may vary according to the color emitted from the organic light emitting member. In the case of white light, materials each emitting one of the colors, red, green, and blue are stacked, and the white light is the sum of the red, green, and blue light emitted from the stacked materials. Also, when using an organic light emitting member that emits white light, color filters may be used to obtain light of a desired color.

[0009] However, after passing through the color filters, color purity of light deteriorates due to a limitation in color reproducibility of the color filters.

[0010] The above information, disclosed in this Background section, is provided only for enhancement of understanding of the background of the invention and therefore it may contain information that does not form part of the prior art.

SUMMARY OF THE INVENTION

[0011] The present invention has been made in an effort to provide an organic light emitting device having advantages of improved color reproducibility and improved range of viewing angle.

[0012] The present invention provides an organic light emitting display comprising: a substrate comprising a first region, a second region, a third region, and a fourth region respectively corresponding to a red pixel, a green pixel, a blue pixel, and a white pixel; a thin film transistor array disposed on the substrate and comprising a first driving transistor disposed on the first region, a second driving transistor disposed on the second region, a third driving transistor disposed on the

third region and a fourth driving transistor disposed on the fourth region; an overcoat disposed on the thin film transistor array; first, second, third, and fourth pixel electrodes disposed on and contacting the overcoat, the first pixel electrode disposed at the first region, the second pixel electrode disposed on the second region, the third pixel electrode disposed on the third region, and the fourth pixel electrode disposed on the fourth region, respectively; an organic light emitter disposed on the first, second, third, and fourth pixel electrodes; and a common electrode disposed on the organic light emitter. Thicknesses of the first, third, and fourth pixel electrodes are substantially equal to each other and different from the thickness of the second pixel electrode.

[0013] A refractive index difference between the overcoat and the first to fourth pixel electrodes may be 0.2 or greater.

[0014] The first, second, third, and fourth pixel electrodes may comprise ITO or IZO.

[0015] The overcoat may comprise an organic material.

[0016] The second pixel electrode may be thicker than the first, third, and fourth pixel electrodes.

[0017] The second pixel electrode may comprise a lower transparent electrode and an upper transparent electrode.

[0018] First, second, third, and fourth contact holes formed in the overcoat extend to portions of the first, third, and fourth driving transistors respectively; the first, third, and fourth pixel electrodes comprise a transparent conductor which is disposed in the first, third, and fourth contact holes and contacts the portions of the first, third, and fourth driving transistors respectively; and lower first transparent electrode of the second pixel electrode is disposed on the overcoat and contacts the second driving transistor through the second contact hole.

[0019] The first, second, third, and fourth pixel electrodes may comprise ITO or IZO.

[0020] The overcoat may comprise an organic material.

[0021] First, second, third, and fourth contact holes formed in the overcoat extend to portions of the first, second, third, and fourth driving transistors respectively; the first, third, and fourth pixel electrodes contact the portions of the first, third, and fourth driving transistors through the first, third, and fourth contact holes; and the upper transparent electrode of the second pixel electrode contacts the second driving transistor through the second contact hole.

[0022] The second contact hole may penetrate the lower transparent electrode of the second pixel electrode.

[0023] The first, second, third, and fourth pixel electrodes may comprise ITO or IZO.

[0024] The overcoat may comprise an organic material.

[0025] The thickness of the second pixel electrode may be between about 1400 Å and about 1600 Å, and the thickness of the first, third, and fourth pixel electrodes may be between about 800 Å and about 1000 Å.

[0026] The second pixel electrode may be thinner than the first, third, and fourth pixel electrodes.

[0027] Each of the first, third, and fourth pixel electrodes may comprise a lower transparent electrode and an upper transparent electrode.

[0028] The thickness of the second pixel electrode may be between about 300 Å and about 500 Å, and the thickness of the first, third, and fourth pixel electrodes may be between about 800 Å and about 1000 Å.

[0029] The organic light emitting device may further comprise first, second, and third color filters disposed on the thin film transistor array and disposed at the first, second, and third regions, respectively.

[0030] The organic light emitting device may further comprise a fourth color filter disposed on the thin film transistor array and disposed at the fourth region.

[0031] The organic light emitter may be a white organic light emitting member.

[0032] The organic light emitter may comprise first, second, third, and fourth organic light emitting members disposed at the first, second, third, and fourth regions, respectively.

BRIEF DESCRIPTION OF THE DRAWINGS

[0033] FIG. 1 is an equivalent circuit diagram of an organic light emitting device according to an exemplary embodiment of the present invention.

[0034] FIG. 2 is a plan view illustrating a plurality of pixels in an organic light emitting device according to an exemplary embodiment of the present invention.

[0035] FIG. 3 is a cross-sectional view of an organic light emitting device according to an exemplary embodiment of the present invention.

[0036] FIG. 4 to FIG. 12 are cross-sectional views of an organic light emitting device of FIG. 3 at intermediate steps of a manufacturing method of an organic light emitting device according to an exemplary embodiment of the present invention.

[0037] FIG. 13 is a cross-sectional view of an organic light emitting device according to another exemplary embodiment of the present invention.

[0038] FIG. 14 to FIG. 18 are cross-sectional views of an organic light emitting device of FIG. 13 at intermediate steps of a manufacturing method of an organic light emitting device according to an exemplary embodiment of the present invention.

[0039] FIG. 19 and FIG. 20 are cross-sectional views of organic light emitting devices according to exemplary embodiments of the present invention.

[0040] FIG. 21 is a plan view illustrating a plurality of pixels disposed in an organic light emitting device according to another exemplary embodiment of the present invention.

[0041] FIG. 22 is a cross-sectional view of the organic light emitting device of FIG. 21 according to another exemplary embodiment of the present invention.

DESCRIPTION OF REFERENCE NUMERALS INDICATING PRIMARY ELEMENTS IN THE DRAWINGS

[0042]

110: insulation substrate	112: insulating layer
121: gate line	171: data line
172: driving voltage line	180: overcoat
185R, 185G, 185B, 185W: contact hole	
191R, 191G, 191B, 191W: pixel electrode	
230R, 230G, 230B, 230W: color filter	
270: common electrode	361: insulating member
370, 370R, 370G, 370B, 370W: organic light emitting member	
Cst: storage capacitor	I_{LD} : driving current
LD: organic light emitting element	PX, R, G, B, W: pixel

-continued

Qs, QsR, QsG, QsB, QsW: switching transistor
Qd, QdR, QdG, QdB, QdW: driving transistor

DETAILED DESCRIPTION OF THE EMBODIMENTS

[0043] The present invention will be described more fully hereinafter with reference to the accompanying drawings, in which exemplary embodiments of the invention are shown. As those skilled in the art would realize, the described embodiments may be modified in various different ways, all without departing from the spirit or scope of the present invention.

[0044] In the drawings, the thickness of layers, films, panels, regions, etc., are exaggerated for clarity. Like reference numerals designate like elements throughout the specification. It will be understood that when an element such as a layer, film, region, or substrate is referred to as being "on" another element, it can be directly on the other element or intervening elements may also be present. In contrast, when an element is referred to as being "directly on" another element, there are no intervening elements present.

[0045] First, an organic light emitting device according to an exemplary embodiment of the present invention will be described in detail with reference to FIG. 1.

[0046] FIG. 1 is an equivalent circuit diagram of an organic light emitting device according to an exemplary embodiment of the present invention.

[0047] Referring to FIG. 1, the organic light emitting device according to the present exemplary embodiment includes a plurality of pixels PX that are arranged in a matrix array and connected to a plurality of signal lines 121, 171, and 172.

[0048] The signal lines include a plurality of gate lines 121 for transferring a gate signal (or scanning signal), a plurality of data lines 171 for transferring a data signal, and a plurality of driving voltage lines 172 for transferring a driving voltage. The gate lines 121 extend in a row direction parallel to each other, and the data lines 171 extend in a column direction parallel to each other. Although the driving voltage lines 172 extend in a column direction in FIG. 1, they may extend in a row direction or a column direction, or may be formed in a mesh style.

[0049] Each pixel PX includes a switching transistor Qs, a driving transistor Qd, a storage capacitor Cst, and an organic light emitting element LD.

[0050] The switching transistor Qs includes a control terminal, an input terminal and an output terminal. The control terminal is connected to the gate line 121, the input terminal is connected to the data line 171, and the output terminal is connected to the driving transistor Qd. The switching transistor Qs transfers a data signal received from the data line 171 to the driving transistor Qd in response to a scanning signal from the gate line 121.

[0051] The driving transistor Qd also includes a control terminal, an input terminal, and an output terminal. The control terminal of the driving transistor Qd is connected to the output terminal of the switching transistor Qs, the input terminal of the driving transistor Qd is connected to the driving voltage line 172, and the output terminal of the driving transistor Qd is connected to the organic light emitting element

LD. The driving transistor Qd provides an output current I_{LD} , the magnitude of which is controlled by a voltage applied between the control terminal of the driving transistor Qd and the input terminal of the driving transistor Qd.

[0052] The capacitor Cst is connected between the control terminal and the input terminal of the driving transistor Qd. The capacitor Cst stores a data voltage that is applied between the control terminal and the input terminal of the driving transistor Qd and maintains the stored data voltage even after the switching transistor Qs is turned off.

[0053] The organic light emitting element LD, for example an organic light emitting diode, includes an anode connected to the output terminal of the driving transistor Qd and a cathode connected to a common voltage Vss. The output current I_{LD} passes through the light emitting element LD. The organic light emitting element LD displays images by emitting light with an intensity that is related to the magnitude of output current I_{LD} of the driving transistor Qd. The organic light emitting element LD may include an organic material that uniquely emits light of at least one of a set of primary colors such as red, green, and blue, or may include an organic material that emits white light. The organic light emitting device displays images that include desired colors, the desired colors being a spatial sum of these primary colors.

[0054] Although the switching transistor Qs and the driving transistor Qd are n-channel field effect transistors (FET), at least one of them may be a p-channel field effect transistor. Also, connection relationships among the transistors Qs, and Qd, the capacitor Cst, and the organic light emitting element LD may be modified.

[0055] Hereinafter, a pixel layout of the organic light emitting device of FIG. 1 will be described with reference to FIG. 2.

[0056] FIG. 2 is a plan view illustrating a plurality of pixels disposed in an organic light emitting device according to an exemplary embodiment of the present invention.

[0057] Referring to FIG. 2, an organic light emitting device according to an exemplary embodiment of the present invention includes red pixels R for displaying red, green pixels G for displaying green, blue pixels B for displaying blue and white pixels W for displaying no specific color but for emitting white light, these pixels being alternately arranged on a substrate. The red pixels R, the green pixels G, and the blue pixels B are basic pixels which are used together for displaying a full range of colors. Instead of the three primary colors red, green, and blue, the organic light emitting device may include pixels that emit a different set of three primary colors. The white pixel W is used for enhancing luminance and may be omitted.

[0058] Four pixels including a red pixel R, a green pixel G, a blue pixel B, and a white pixel W can be arranged to form one group such as the group of pixels enclosed by the dashed line in FIG. 2. Such groups of four pixels may be arranged in columns and rows. However, the pixel layout may be modified in various ways.

[0059] Hereinafter, details of a structure of the organic light emitting device shown in FIG. 1 and FIG. 2 will be described with reference to FIG. 3.

[0060] FIG. 3 is a cross-sectional view including a composite of four cross-sections including a cross-section of a red pixel R, a cross-section of a green pixel G, a cross-section of a blue pixel B, and a cross-section of a white pixel W of an organic light emitting device according to an exemplary embodiment of the present invention.

[0061] The organic light emitting device includes an insulating substrate 110 that may be made of transparent glass or plastic. The insulating substrate 110 includes first regions 110R, second regions 110G, third regions 110B and fourth regions 110W. A red pixel R is disposed on each first region 110R, a green pixel G is disposed on each second region 110G, a blue pixel B is disposed on each third region 110B, and a white pixel W is disposed on each fourth region 110W. A thin film transistor array including a plurality of switching transistors QsR, QsG, QsB, and QsW and a plurality of driving transistors QdR, QdG, QdB, and QdW are disposed on the insulating substrate 110. The red pixel R includes a first switching transistor QsR and a first driving transistor QdR. The green pixel G includes a second switching transistor QsG and a second driving transistor QdG. The blue pixel B includes a third switching transistor QsB and a third driving transistor QdB. The white pixel W includes a fourth switching transistor QsW and a fourth driving transistor QdW. Although not shown in FIG. 3, the first switching transistor QsR and the first driving transistor QdR are electrically connected to each other. The first switching transistor QsR and the first driving transistor QdR may be connected together as previously described and further description is omitted here. Likewise the switching transistors QsG, QsB and QsW are connected to the driving transistors QdG, QdB and QdW, respectively.

[0062] An insulating layer 112 is disposed on the thin film transistor array including the switching transistors QsR, QsG, QsB, and QsW and the driving transistors QdR, QdG, QdB, and QdW.

[0063] On the insulating layer 112, the red pixel R includes a red color filter 230R also referred to as a first color filter, the green pixel G includes a green color filter 230G also referred to as a second color filter, the blue pixel B includes a blue color filter 230B also referred to as a third color filter, and the white pixel W includes a transparent white color filter 230W also referred to as a fourth color filter. The white color filter 230W of the white pixel W may be omitted.

[0064] An overcoat 180 is disposed on the color filters 230R, 230G, 230B, and 230W, and on the insulating layer 112. The overcoat 180 may be made of an organic material and may have a flat surface.

[0065] A plurality of contact holes including a first contact hole 185R, a second contact hole 185G, a third contact hole 185B, and a fourth contact hole 185W are formed in the overcoat 180 and the insulating layer 112, and extend to a portion of the output terminal (not shown) of the driving transistors QdR, QdG, QdB and QdW, respectively.

[0066] Pixel electrodes, including a first pixel electrode 191R, a second pixel electrode 191G, a third pixel electrode 191B, and a fourth pixel electrode 191W are disposed on the overcoat 180, and are located above the color filters 230R, 230G, 230B, and 230W, respectively.

[0067] Each of the pixel electrodes 191R, 191B, and 191W of the red, blue, and white pixels R, B, and W includes a lower transparent electrode and an upper transparent electrode. The pixel electrodes 191R, 191B, and 191W include a first lower transparent electrode 192R, a third lower transparent electrode 192B, and a fourth lower transparent electrode 192W, respectively at the bottom thereof and a first upper transparent electrode 193R, a third upper transparent electrode 193B, and a fourth upper transparent electrode 193W at the top thereof.

[0068] The second pixel electrode **191G** of the green pixel **G** includes a transparent electrode **193G** formed of a single layer and a transparent conductor **192G** disposed in the contact hole **185G**.

[0069] The lower transparent electrodes **192R**, **192B**, and **192W** of the red, blue, and white pixels **R**, **B**, and **W** are disposed on the overcoat **180** and in the contact holes **185R**, **185B**, and **185W**, and are electrically connected to the driving transistors **QdR**, **QdB** and **QdW** through the contact holes **185R**, **185B**, and **185W**, respectively. The upper transparent electrodes **193R**, **193B**, and **193W** are respectively disposed on the lower transparent electrodes **192R**, **192B**, and **192W**, and also may in part be disposed on the overcoat **180**.

[0070] The transparent conductor **192G** of the green pixel **G** is not present on the overcoat **180** but is disposed only in the second contact hole **185G**. The transparent electrode **193G** is disposed on the transparent conductor **192G** and on the overcoat **180**, and is electrically connected to the driving transistor **QdG** via the transparent conductor **192G**.

[0071] The lower transparent electrodes **192R**, **192B**, **192W**, and the transparent conductor **192G** may be formed in a first layer of transparent conductive material, the upper transparent electrodes **193R**, **193B**, and **193W**, and the transparent electrode **193G** may be formed in a second layer of transparent conductive material. The first layer and the second layer of transparent conductive material may be made of a transparent conductive material such as indium tin oxide (ITO) or indium zinc oxide (IZO).

[0072] As shown in FIG. 3, a thickness D_g of the pixel electrode **191G** of the green pixel **G** is less than that of the pixel electrodes **191R**, **191B**, and **191W** of the red, blue, and white pixels **R**, **B**, and **W**. The thickness D_g of the pixel electrode **191G** may be between about 300 Å and about 500 Å, and the thicknesses D_r , D_b , and D_w of the pixel electrodes **191R**, **191B**, and **191W** may be between about 800 Å and about 1000 Å. The thicknesses D_r , D_b , and D_w are substantially equal.

[0073] Alternatively, each of the pixel electrodes **191R**, **191G**, **191B**, and **191W** may be formed of a single layer including ITO or IZO. In this case, the thickness D_g of the pixel electrode **191G** may be also thinner than the thicknesses D_r , D_b , and D_w of the pixel electrodes **191R**, **191B**, and **191W**.

[0074] The pixel electrodes **191R**, **191G**, **191B**, and **191W** have a refractive index that is greater than the refractive index of the overcoat **180**. The refractive index difference therebetween may be 0.2 or greater. For example, when a refractive index of the overcoat **180** made of an organic layer is between about 1.5 and about 1.7, a refractive index of the pixel electrodes **191R**, **191G**, **191B**, and **191W** made of ITO or IZO may be between about 1.8 and about 2.3. Due to the refractive index difference between the overcoat **180** and the pixel electrodes **191R**, **191G**, **191B**, and **191W**, at least a portion of incident light entering the pixel electrodes **191R**, **191G**, **191B**, and **191W** from above is reflected at the interface or boundary between the pixel electrodes **191R**, **191G**, **191B** and **191W** and the overcoat **180**.

[0075] A plurality of insulating members **361** are disposed on the overcoat **180** between the adjacent pixel electrodes **191R**, **191G**, **191B**, and **191W** to provide insulation between the pixel electrodes **191R**, **191B**, **191G**, and **191W**. The insulating members **361** may be omitted.

[0076] A light emitter is disposed on the insulating members **361** and the pixel electrodes **191R**, **191G**, **191B**, and

191W. The light emitter may be an organic light emitter, which in this embodiment is a white organic light emitting member **370**. A common electrode **270**, to which a common voltage V_{ss} may be applied, is disposed on the white organic light emitting member **370**.

[0077] The white organic light emitting member **370** may have a stacked structure that includes a plurality of organic material layers each emitting a different color from a set of primary colors. The common electrode **270** may be made of a reflective metal including calcium (Ca), barium (Ba), magnesium (Mg), aluminum (Al), or silver (Ag).

[0078] Alternatively, the organic light emitter may include organic light emitting members (not shown) including red, green and blue light emitting members, and a white organic light emitting member, that may be disposed in the red, green, blue, and white pixels **R**, **G**, **B**, and **W**, respectively. In this case, the red, green, and blue color filters **230R**, **230G**, and **230B**, and the white color filter **230W**, may be omitted.

[0079] In the organic light emitting device shown in FIG. 3, the pixel electrodes **191R**, **191G**, **191B**, and **191W**, the organic light emitting member **370**, and the common electrode **270** form organic light emitting elements LD, wherein the pixel electrodes **191R**, **191G**, **191B**, and **191W** are anodes. Also, the common electrode **270** is a common cathode that is shared by the light emitting elements LD.

[0080] Such an organic light emitting device emits light in a downward direction through the insulating substrate **110**, thereby displaying images. The light emitted from the organic light emitting member **370** toward the substrate **110** passes through the pixel electrodes **191R**, **191G**, **191B**, and **191W** and reaches a boundary between the pixel electrodes **191R**, **191G**, **191B**, and **191W** and the overcoat **180**. At the boundary, light is reflected toward the common electrode **270**, and at the common electrode **270** this light is reflected again so that the light again reaches the boundary between the pixel electrodes **191R**, **191G**, **191B**, and **191W** and the overcoat **180**. In this way, light that is repeatedly reflected at the common electrode **270** and at the boundary between the pixel electrodes **191R**, **191G**, **191B**, and **191W** and the overcoat **180**, as described above, undergoes an optical process such as interference, and as a result, a predetermined wavelength of light may be intensified. Light with an intensified predetermined wavelength is emitted after passing out of the overcoat **180** and this modified light then passes through the color filters **230R**, **230G**, **230B**, and **230W**.

[0081] The optical path lengths are dependent on thicknesses and refractive indexes of the thin films disposed between the overcoat **180** and the common electrode **270**. It is possible to obtain desired optical characteristics, for example, a desired range of wavelengths and a desired color purity for respective wavelengths, by properly controlling the thicknesses D_r , D_g , D_b , and D_w of the pixel electrodes **191R**, **191G**, **191B**, and **191W** as well as the thickness of the organic light emitting member **370** while particularly controlling the thickness D_g of the pixel electrode **191G** of the green pixel **G** to be different from the thicknesses D_r , D_b , and D_w of the pixel electrodes **191R**, **191B**, and **191W** of the other pixels **R**, **B**, and **W**. Also, light transmittance of a desired range of wavelengths for each of the primary colors including green may be increased, and color variation at side viewing angles may be reduced.

[0082] In particular, as the refractive index difference between the overcoat **180** and the pixel electrodes **191R**, **191G**, **191B**, and **191W** is made greater, it is possible to

further increase the reflectance at the boundary between the overcoat **180** and the pixel electrodes **191R**, **191G**, **191B**, and **191W** and thus further improve the color purity.

[0083] Hereinafter, a manufacturing method of manufacturing the organic light emitting device of FIG. **3** will be described with reference to FIG. **4** to FIG. **12**.

[0084] FIG. **4** to FIG. **12** are cross-sectional views of an organic light emitting device of FIG. **3** in intermediate steps of a manufacturing method of an organic light emitting device according to an exemplary embodiment of the present invention.

[0085] Referring FIG. **4**, a thin film transistor array including a plurality of switching transistors **QsR**, **QsG**, **QsB** and **QsW** and a plurality of driving transistors **QdR**, **QdG**, **QdB**, and **QdW** is formed on a substrate **110**.

[0086] Referring to FIG. **5**, an insulating layer **112** is deposited on the thin film transistor array and a plurality of color filters **230R**, **230G**, **230B**, and **230W** are formed on the insulating layer **112**.

[0087] Referring to FIG. **6** and FIG. **7**, an overcoat **180** is formed on the insulating layer **112** and on the color filters **230R**, **230G**, **230B**, and **230W**. Then, a plurality of contact holes **185R**, **185G**, **185B**, and **185W** are formed by patterning the insulating layer **112** and the overcoat **180**. The contact holes **185R**, **185G**, **185B**, and **185W** extend through the overcoat **180** and the insulating layer **112** to the output terminals (not shown) of the driving transistors **QdR**, **QdG**, **QdB**, and **QdW**, respectively.

[0088] Referring to FIG. **8**, a first transparent conductive layer **190p** made of ITO or IZO is formed on the overcoat **180** by, for example, a sputter deposition process.

[0089] Then, a first photosensitive film is coated on the first transparent conductive layer **190p**, and a first photoresist pattern **40a** is formed by patterning the first photosensitive film.

[0090] Referring to FIG. **9**, a plurality of lower transparent electrodes **192R**, **192B**, and **192W** and transparent conductors **192G** are formed by etching the first transparent conductive layer **190p** while using the first photoresist pattern **40a** as a mask. Here, the transparent conductor **192G** of the green pixel **G** is left in the contact hole **185G** by terminating the etching process when the etching process penetrates to the overcoat **180**.

[0091] Referring to FIG. **10**, a second transparent conductive layer **190q** made of ITO or IZO is deposited on the lower transparent electrodes **192R**, **192B**, and **192W**, the transparent conductor **192G**, and the overcoat **180**, for example by sputtering. Then, a second photoresist pattern **50a** is formed on the second transparent conductive layer **190q** by coating and patterning a second photosensitive film on the second transparent conductive layer **190q**.

[0092] Referring to FIG. **11**, a plurality of the upper transparent electrodes **193R**, **193B**, and **193W** and transparent electrodes **193G** are formed by etching the second transparent conductive layer **190q** using the second photoresist pattern **50a** as a mask, thereby completely forming pixel electrodes **191R**, **191G**, **191B**, and **191W** of pixels **R**, **G**, **B**, and **W**, respectively.

[0093] Referring to FIG. **12**, an insulating layer is coated on the pixel electrodes **191R**, **191G**, **191B**, and **191W**, and the overcoat **180**, and a plurality of insulating members **361** are formed by patterning the insulating layer. The insulating members **361** extend between adjacent pixel electrodes and around the perimeter of each pixel electrode.

[0094] Finally, as shown in FIG. **3**, an organic light emitter including a white organic light emitting member **370** and a common electrode **270** are sequentially formed on the pixel electrodes **191R**, **191G**, **191B**, and **191W**, and on insulating members **361**.

[0095] As described above, the transparent conductor **192G** is left in the contact hole **185G** of the green pixel **G** when the lower transparent electrodes **192R**, **192B**, and **192W** are formed. Therefore, the output terminal of the driving transistor **QdG** is protected from being exposed to an etchant used for etching the first transparent conductive layer **190p** and is thus protected from being damaged by the etchant.

[0096] An organic light emitting device according to another exemplary embodiment of the present invention will be described with reference to FIG. **1**, FIG. **2** and FIG. **13**.

[0097] FIG. **13** is a cross-sectional view of an organic light emitting device according to another exemplary embodiment of the present invention.

[0098] The descriptions already provided of like elements in the previous embodiment are omitted here, and like reference numerals are designated to like constituent elements.

[0099] A thin film transistor array, an insulating layer **112**, a plurality of color filters **230R**, **230G**, and **230B**, an overcoat **180**, pixel electrodes **191R**, **191G**, **191B**, and **191W**, insulating members **361**, an organic light emitter including a white organic light emitting member **370**, and a common electrode **270** are sequentially disposed on an insulating substrate **110**.

[0100] In the organic light emitting device according to the present exemplary embodiment, red color filters **230R**, green color filters **230G**, and blue color filters **230B** are disposed on the insulating layer **112**. However, no color filter is provided in the white pixel **W**. Alternatively, a white color filter may be provided in the white pixel **W**.

[0101] Also, structures of the contact holes **185R**, **185G**, **185B**, and **185W** and the pixel electrodes **191R**, **191G**, **191B**, and **191W** in the present embodiment are different from those in the previously described exemplary embodiment shown in FIG. **3**.

[0102] Although the pixel electrodes **191R**, **191B**, and **191W** of the red, blue, and white pixels **R**, **B**, and **W** respectively include a lower transparent electrode **192R**, **192B** and **192W** and an upper transparent electrode **193R**, **193B** and **193W**, the pixel electrode **191G** of the green pixel **G** is made of a single layer of a transparent conductive material.

[0103] Although the contact holes **185R**, **185B**, and **185W** of the red, blue and white pixels **R**, **B** and **W** penetrate the insulating layer **112**, the overcoat **180**, and the first transparent electrodes **192R**, **192B**, and **192W**, the contact hole **185G** of the green pixel **G** penetrates only the insulating layer **112** and the overcoat **180**. The upper transparent electrodes **193R**, **193B**, and **193W** of the red, blue, and white pixels **R**, **B**, and **W** are electrically connected to the driving transistors **QdR**, **QdB**, and **QdW** through the contact holes **185R**, **185B**, and **185W**, respectively, and the pixel electrode **191G** of the green pixel **G** is electrically connected to the driving transistor **QdG** through the contact hole **185G**.

[0104] The thicknesses **Dr**, **Dg**, **Db**, and **Dw** of the pixel electrodes **191R**, **191G**, **191B**, and **191W** are similar to those of the previous exemplary embodiment shown in FIG. **3**.

[0105] Now, a manufacturing method of the organic light emitting device of FIG. **13** will be described with reference to FIG. **14** to FIG. **18**.

[0106] FIG. **14** to FIG. **18** are cross-sectional views of the organic light emitting device of FIG. **13** at intermediate steps

of a manufacturing method of an organic light emitting device according to an exemplary embodiment of the present invention.

[0107] Referring to FIG. 14, as in the previous exemplary embodiment, a thin film transistor array is formed on an insulating substrate 110. Then, an insulating layer 112, a plurality of color filters 230R, 230G, and 230B, and an overcoat 180 are sequentially formed.

[0108] The first transparent conductive layer 190r is deposited on the overcoat 180, and a first photoresist pattern 40b is formed by coating a first photosensitive film on the first transparent conductive layer 190r and patterning the first photosensitive film.

[0109] Referring to FIG. 15, a plurality of lower transparent electrodes 192R, 192B, and 192W are formed at the red, blue, and white pixels R, B, and W by etching the first transparent conductive layer 190r while using the first photoresist pattern 40b as a mask.

[0110] Referring to FIG. 16 and FIG. 17, a second photoresist pattern 45a is formed by coating a second photosensitive film on the lower transparent electrodes 192R, 192B, and 192W, and on the overcoat 180, and patterning the second photosensitive film.

[0111] Then, a plurality of contact holes 185R, 185G, 185B, and 185W are formed in the lower transparent electrodes 192R, 192B, and 192W, the overcoat 180, and the insulating layer 112 by etching while using the second photoresist pattern 45a as a mask. Since the contact holes 195R, 185G, 185B, and 185W are formed after the lower transparent electrodes 192R, 192B, and 192W are formed, the driving transistors QdR, QdB, and QdW are prevented from being damaged by an etchant that is used for patterning the lower transparent electrodes 192R, 192B, and 192W.

[0112] Referring to FIG. 18, a second transparent conductive layer made of ITO or IZO is deposited on the lower transparent electrodes 192R, 192B, and 192W, and the overcoat 180, and a photoresist pattern (not shown) is formed thereon. Then, a plurality of upper transparent electrodes 193R, 193B, and 193W and pixel electrodes 191G of the green pixel G are formed by etching the second transparent conductive layer using the photoresist pattern (not shown) as a mask. The lower transparent electrodes 192R, 192B, and 192W and the upper transparent electrodes 193R, 193B, and 193W of the red, blue, and white pixels R, B, and W form the pixel electrodes 191R, 191B, and 191W, respectively.

[0113] Finally, as shown in FIG. 13, a plurality of insulating members 361, a white organic light emitting member 370, and a common electrode 270 are sequentially formed on the pixel electrodes 191R, 191G, 191B, and 191W and the overcoat 180.

[0114] An organic light emitting device according to two other exemplary embodiments will be described with reference to FIG. 19 and FIG. 20 as well as FIG. 1 and FIG. 2.

[0115] FIG. 19 and FIG. 20 are cross-sectional views of organic light emitting devices according to exemplary embodiments of the present invention.

[0116] The descriptions of like elements previously described are here omitted, and like reference numerals are designated to like constituent elements.

[0117] Referring to FIG. 19, an organic light emitting device according to the present exemplary embodiment has a structure that is similar to that shown in FIG. 3 except for the pixel electrodes 191R, 191G, 191B, and 191W.

[0118] Unlike the organic light emitting device shown in FIG. 3, the pixel electrode 191G of the green pixel G includes a lower transparent electrode 194G and an upper transparent electrode 195G, and the pixel electrodes 191R, 191B, and 191W of the red, blue, and white pixels R, B, and W respectively include transparent electrodes 195R, 195B, and 195W made of a single second transparent conductive layer and transparent conductors 194R, 194B, and 194W made from a first transparent conductive layer and disposed in the respective contact holes 185R, 185B, and 185W.

[0119] In the present exemplary embodiment, a thickness Dg of the pixel electrode 191G of the green pixel G is greater than that of the pixel electrodes 191R, 191B, and 191W of the red, blue, and white pixels R, B, and W. The thickness Dg of the pixel electrode 191G may be between about 1400 Å and about 1600 Å, and the thicknesses Dr, Db, and Dw of the red, blue, and white pixels R, B, and W may be between about 800 Å and about 1000 Å. The thicknesses Dr, Db, and Dw are substantially equal.

[0120] In the previous exemplary embodiments shown in FIGS. 3 and 13, light that is reflected repeatedly at a boundary between the green pixel electrode 191G and the overcoat 180 and at the common electrode 270 is finally emitted as light that contains a strong green component which is then separated by a green filter. In the previous exemplary embodiments the green pixel electrode is between about 300 Å and about 500 Å thick and has an index of refraction between 1.5 and 1.7.

[0121] In the present embodiment, the green pixel G has a different optical path length from the previous embodiments. The thickness of the green pixel electrode is increased to between about 1400 Å and about 1600 Å while the index of refraction is again between about 1.5 and about 1.7, and light experiences an optical process such as constructive interference under different conditions to again be emitted from the green pixel electrode 191G as light that contains a strong green component. Therefore, it is possible to obtain light having a desired range of wavelength and desired color purity for respective primary colors including green. Also, it is possible to reduce color variation and to improve transmittance.

[0122] Also, in the present exemplary embodiment, color filters are omitted in the white pixel W although red color filters 230R, green color filters 230G, and blue color filters 230B are disposed on the insulating layer 112.

[0123] Next, referring to FIG. 20, an organic light emitting device according to another exemplary embodiment that is similar to the organic light emitting device of FIG. 19 except for the color filters 230R, 230G, 230B, and 230W, the pixel electrodes 191R, 191G, 191B, and 191W, the insulating members 361, and the organic light emitting members 370R, 370G, 370B, and 370W.

[0124] In the organic light emitting device according to the present exemplary embodiment as shown in FIG. 20, color filters including red color filters 230R, green color filters 230G, blue color filters 230B, and white color filters 230W are disposed on the insulating layer 112.

[0125] The pixel electrode 191G of the green pixel G includes a lower transparent electrode 194G formed in a first layer of transparent conductive material at a lower side and an upper transparent electrode 195G formed in a second layer of transparent conductive material at an upper side. The pixel electrodes 191R, 191B, and 191W of red, blue, and white pixels R, B, and W are made of a single layer of a transparent conductive material, which layer may be the second layer.

[0126] Also, while the contact holes **185R**, **185B**, and **185W** of the red pixel R, the blue pixel B, and the white pixel W penetrate the insulating layer **112** and the overcoat **180**, the contact hole **185G** of the green pixel G penetrates the insulating layer **112**, the overcoat **180**, and the lower transparent electrode **194G**. The upper transparent electrode **195G** of the green pixel G is connected to the driving transistor QdG through the contact hole **185G**, and the pixel electrodes **191R**, **191B**, and **191W** of the red pixel R, the blue pixel B, and the white pixel W are electrically connected to driving transistors QdR, QdB, and QdW through the contact holes **185R**, **185B**, and **185W**, respectively.

[0127] The thicknesses Dr, Dg, Db, and Dw of the pixel electrodes **191R**, **191G**, **191B**, and **191W** may be substantially the same as those of the organic light emitting device of FIG. **19**.

[0128] A plurality of insulating members **361** is disposed on the overcoat **180** between adjacent pixel electrodes **191R**, **191G**, **191B**, and **191W**. Each insulating member **361** defines an opening by surrounding the edges of the pixel electrodes **191R**, **191G**, **191B**, and **191W**, and may be made of an organic insulator or an inorganic insulator.

[0129] In this embodiment, the organic light emitter includes red, green, blue, and white organic light emitting members **370R**, **370G**, **370B**, and **370W** disposed in the openings that are surrounded by the insulating members **361** at the red pixel R, the green pixel G, the blue pixel B, and the white pixel W, respectively. The red, green, blue, and white organic light emitting members **370R**, **370G**, **370B**, and **370W** are made of organic materials each uniquely emitting one of red, green, blue, and white light. The white organic light emitting member **370W** may have a stacked structure of a plurality of organic material layers each emitting a different color of light.

[0130] In such a way, organic light emitting members **370R**, **370G**, **370B**, and **370W** each of which uniquely emits one of red, green, blue, and white light are disposed at pixels R, G, B, and W, respectively. Therefore, color reproducibility may be further improved.

[0131] The white color filters **230W** of the white pixels W may be omitted.

[0132] Alternatively, the red, green, blue, and white color filters **230R**, **230G**, **230B**, and **230W** may be omitted.

[0133] With reference to FIG. **21** and FIG. **22**, an organic light emitting device according to another exemplary embodiment of the present invention will be described in detail.

[0134] FIG. **21** is a plan view illustrating a plurality of pixels disposed in an organic light emitting device according to another exemplary embodiment of the present invention, and FIG. **22** is a cross-sectional view of the organic light emitting device according to this exemplary embodiment of the present invention.

[0135] Referring to FIG. **21**, an organic light emitting device includes red pixels R, green pixels G, and blue pixels B, which are disposed in that order in rows of pixels.

[0136] The three pixels including a red pixel R, a green pixel G, and a blue pixel B form one group, and the group of pixels R, G and B is disposed repeatedly along the rows and columns. Adjacent rows are offset so that columns include groups of pixels R, G, and B. However, the pixel layout and the pixel shape may be modified in various ways.

[0137] Referring to FIG. **22**, an organic light emitting device according to the present exemplary embodiment has a stacked structure that is similar to that of the organic light emitting device of FIG. **20**.

[0138] However, the organic light emitting device according to the present exemplary embodiment includes only pixels of three colors, red, green, and blue pixels R, G, and B. Since the pixel electrodes **191R**, **191G**, and **191B** and the organic light emitting members **370R**, **370G**, and **370B** are the same as those of the organic light emitting device shown in FIG. **20**, further descriptions thereof are omitted.

[0139] Various features of the organic light emitting device of FIG. **20** may be applied to the organic light emitting device of the present exemplary embodiment.

[0140] Various features of the organic light emitting device and the manufacturing method thereof shown in FIG. **1** to FIG. **18** may be applied to the organic light emitting devices shown in FIG. **19** to FIG. **22**. Also, color filters of the organic light emitting device and the structure and arrangement of the organic light emitting members according to various exemplary embodiments of the present invention may be modified in various ways.

[0141] In this way, display characteristics such as color reproducibility and viewing angle characteristics of an organic light emitting device may be improved. Also, during a manufacturing process of an organic light emitting device, thin film transistors may be prevented from being damaged.

[0142] While this invention has been described in connection with what is presently considered to be practical exemplary embodiments, it is to be understood that the invention is not limited to the disclosed embodiments, but, on the contrary, is intended to cover various modifications and equivalent arrangements included within the spirit and scope of the appended claims.

What is claimed is:

1. An organic light emitting display, comprising:

a substrate including a first region, a second region, a third region, and a fourth region on which are disposed a red pixel, a green pixel, a blue pixel, and a white pixel, respectively;

a thin film transistor array disposed on the substrate and comprising a first driving transistor disposed on the first region, a second driving transistor disposed on the second region, a third driving transistor disposed on the third region and a fourth driving transistor disposed on the fourth region;

an overcoat disposed on the thin film transistor array; first, second, third, and fourth pixel electrodes disposed on and contacting the overcoat, the first pixel electrode being disposed on the first region, the second pixel electrode being disposed on the second region, the third pixel electrode being disposed on the third region, and the fourth pixel electrode being disposed on the fourth region;

an organic light emitter disposed on the first, second, third, and fourth pixel electrodes; and

a common electrode disposed on the organic light emitter, wherein thicknesses of the first, third, and fourth pixel electrodes are substantially equal to each other and different from a thickness of the second pixel electrode.

2. The organic light emitting device of claim 1, wherein a refractive index difference between the overcoat and the first, second, third and fourth pixel electrodes is 0.2 or greater.

3. The organic light emitting device of claim 2, wherein the first, second, third, and fourth pixel electrodes comprise ITO or IZO.

4. The organic light emitting device of claim 3, wherein the overcoat comprises an organic material.

5. The organic light emitting device of claim 2, wherein the second pixel electrode is thicker than the first, third, and fourth pixel electrodes.

6. The organic light emitting device of claim 5, wherein the second pixel electrode comprises a lower transparent electrode and an upper transparent electrode.

7. The organic light emitting device of claim 6, wherein first, second, third, and fourth contact holes, formed in the overcoat, expose portions of the first, second, third and fourth driving transistors, respectively,

the first, third, and fourth pixel electrodes each comprise a transparent conductor which is disposed in the first, third, and fourth contact holes and contacts the portions of the first, third and fourth driving transistors, respectively, and

the lower transparent electrode of the second pixel electrode is disposed on the overcoat and contacts the second driving transistor through the second contact hole.

8. The organic light emitting device of claim 7, wherein the first, second, third, and fourth pixel electrodes comprise ITO or IZO.

9. The organic light emitting device of claim 8, wherein the overcoat comprises an organic material.

10. The organic light emitting device of claim 6, wherein first, second, third, and fourth contact holes, formed in the overcoat, expose portions of the first, second, third, and fourth driving transistors, respectively,

the first, third, and fourth pixel electrodes contact the portions of the first, third, and fourth driving transistors through the first, third, and fourth contact holes, and the upper transparent electrode of the second pixel electrode contacts the second driving transistor through the second contact hole.

11. The organic light emitting device of claim 10, wherein the second contact hole penetrates the lower transparent electrode of the second pixel electrode.

12. The organic light emitting device of claim 11, wherein the first, second, third, and fourth pixel electrodes comprise ITO or IZO.

13. The organic light emitting device of claim 12, wherein the overcoat comprises an organic material.

14. The organic light emitting device of claim 5, wherein the thickness of the second pixel electrode is between about 1400 Å and about 1600 Å, and the thickness of the first, third, and fourth pixel electrodes is between about 800 Å and about 1000 Å.

15. The organic light emitting device of claim 2, wherein the second pixel electrode is thinner than the first, third, and fourth pixel electrodes.

16. The organic light emitting device of claim 15, wherein each of the first, third, and fourth pixel electrodes comprises a lower transparent electrode and an upper transparent electrode.

17. The organic light emitting device of claim 15, wherein the thickness of the second pixel electrode is between about 300 Å and about 500 Å, and the thickness of the first, third, and fourth pixel electrodes is between about 800 Å and about 1000 Å.

18. The organic light emitting device of claim 1, further comprising first, second, and third color filters disposed on the thin film transistor array and disposed at the first, second, and third regions, respectively.

19. The organic light emitting device of claim 18, further comprising a fourth color filter disposed on the thin film transistor array and disposed at the fourth region.

20. The organic light emitting device of claim 18, wherein the organic light emitter is a white organic light emitting member.

* * * * *

专利名称(译)	有机发光二极管显示器及其制造方法		
公开(公告)号	US20100053044A1	公开(公告)日	2010-03-04
申请号	US12/470429	申请日	2009-05-21
[标]申请(专利权)人(译)	李海YEON LEE BAEK WOON HWANG杨		
申请(专利权)人(译)	李海YEON 李BAEK垣 HWANG YOUNG-IN		
当前申请(专利权)人(译)	李海YEON 李BAEK垣 HWANG YOUNG-IN		
[标]发明人	LEE HAE YEON LEE BAEK WOON HWANG YOUNG IN		
发明人	LEE, HAE-YEON LEE, BAEK-WOON HWANG, YOUNG-IN		
IPC分类号	G09G3/30		
CPC分类号	G09G3/3233 G09G2300/0452 G09G2300/0842 H01L27/3213 H01L27/3244 H01L51/5259 H01L51/5265 H01L2227/323 H01L27/32 H01L27/3241 H01L27/3248 H01L51/5203		
优先权	1020080085859 2008-09-01 KR		
其他公开文献	US8803415		
外部链接	Espacenet USPTO		

摘要(译)

有机发光二极管显示面板包括透明基板，在该透明基板上形成像素矩阵阵列，每个像素包括有机发光二极管（OLED）。OLEDs包括夹在由透明导电材料制成的像素电极或阳极和由导电材料制成的公共电极之间的发光区域。像素电极的折射率高于其上设置有像素电极的绝缘层的折射率，使得光在像素电极和绝缘层之间的界面处以及在发光之间的界面处经历多次反射。区域和公共电极。选择像素电极的厚度，使得在多次反射之后最终离开像素电极的光包含所选原色的相对强的分量。

